



Helpful tips for Baumfolder Model 714

- Folder not running
- Not Feeding (air models)
- Feeding Doubles
- Not folding square (older models)
- Not folding square (714XE and 714XLT Folders)
- Marking
- Wrinkles
- Paralleling Fold Rolls
- Not Stacking Properly
- Setup to Score and Setup to Perforate diagrams
- Parts Order form

Before working on the folder, **DISCONNECT ALL ELECTRICAL POWER TO THE FOLDER to prevent the accidental start of the folder.** Check to be sure you have the correct tools to complete the job.

For reasons of safety, long hair must be tied back or otherwise secured, garments must be close fitting and no jewelry, such as rings or necklaces, may be worn while adjusting or setting up equipment. Injury may result from being caught up in the machinery or jewelry catching in moving parts.

For more information or to order parts phone Baum at 1-800-543-6107

Baumfolder Corporation

1660 Campbell Rd
Sidney, Ohio, U.S.A. 45365
Phone: 1-800-543-6107 or 1-937-492-1281
Fax: 1-937-492-7280

..... A folder built like a floor model folder that sits on a table.



BAUMFOLDER
SOLUTIONS

Helpful tips for Baumfolder Model 714

► Folder isn't running

Rotate the hand wheel to see if the folder turns freely,

1. If the folder doesn't turn freely:
 - A. Check rollers for jam up.
 - B. Lubricate each bearing on the end of the rollers and any moving part.
 - C. Remove the slitter shaft and see if it turns freely. If it doesn't, clean and lubricate.
Before you replace the slitter shafts, turn the folder by the hand wheel to be sure the bind is not in the slitter shaft. When you replace the slitter shaft, just fingers tighten the black thumbscrew.
 - D. If it still binds, call you local Baum dealer.
2. If the folder turns freely but doesn't run.
 - A. Have your electrician to check the receptacle to be sure the power supply is 115 volts. If not, it's not a problem with the folder. **An electrician should check this.**
 - B. If you are using an extension cord, check to be sure that the cord is rated for 20 amps.
 - C. Have your electrician to check the fuse in the folder to see if it is blown. If so, replace the fuse.
 - D. If the folder still doesn't run, call your Baum dealer.

► Not feeding (air feed)

- A. Check pump to see if.
 - (1) Filters clean (2) vacuum lines clean (3) does the pump need flushed out? The different type pumps are cleaned differently. Check with your dealer for the best way to clean your folder pump.
- B. The caliper assembly should be 90 degrees with the feed table. Use a small carpenter square to check this. If the top of the caliper assembly is tilted toward the paper, the folder will feed doubles and you will not be able to adjust the caliper. If the bottom of the caliper assembly is toward the paper, the paper will not drop down against the feed wheel.
- C. Check the adjustment of the front blow tube (just behind the caliper). It should be separating the bottom sheets.
- D. Check to see if the side guides of the feeder is set to tight not allowing the sheets to slide.
- E. If your folder is a newer model, check to be sure that you have air out of the side guides. If not clean the side air holes.
- F. Remove the stock from the feeder and air the sheets to be sure the sheets are not sticking together due to cutting the stock with a dull cutter blade, or to much ink causing sheets sticking together.

Helpful tips for Baumfolder Model 714

Not feeding - air feed (continued)

- G. On the older folders, check to see if the vacuum is timed correctly.
1. Line up the front edge of the holes in the sucker wheel with the orange tab (the side you put the paper against).
 2. Next lay a sheet of 20 lb. Bond paper on the feed table to cover the first set of sucker wheel holes with the leading edge of the paper.
 3. Turn on the pump (not the folder).
 4. Then turn the hand wheel until leading edge of the paper is past the orange tab. The vacuum should release when the leading edge of the paper is 1/8" past the orange tab.
 5. If not, remove the feed table and loosen the setscrew in the sucker wheel block closest to the folder rolls 1/4 turn. Tighten the setscrew farthest from the fold Rollers 1/4 turn. **NOTE:** Make sure the feed block has a little rotational movement (1/32"). If not, loosen the screws. Repeat 1/4 turns, one way or the other until the 1/8" setting is obtained.

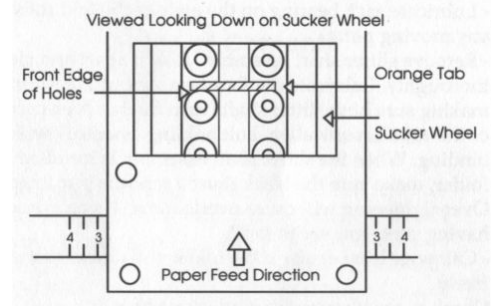

► Feeding doubles (air feed)

- A. Front blow not set properly. Try to separate the bottom sheets.
- B. Side blow not turned on.
- C. Too much vacuum.
- D. Caliper not set 90 degrees to feed table, so caliper is not directly over feed wheel.
- E. Set caliper so one sheet will feed (slide back and forth with very slight drag) but will not allow two sheets through.

► Feeding doubles (friction feed)

- A. Too much distance between the feed wheel and the retarder roll. Loosen the black knob in front of the feed roll assembly and raise the feed wheel by turning the Black-adjusting knob on top of the feed wheel assembly counterclockwise. Hold a sheet by the back of the paper with the leading edge under the feed wheel. Do not hold the paper too tight. Start the folder and turn the black adjusting knob clockwise slowly until the feed tire pulls the sheet from between your fingers. Turn the folder off and tighten the black knob in front of the feed wheel assembly.
- B. If the rear top roll is down against the bottom rear feed roll, the last 8 to 10 sheets will all try to feed at the same time. This roll should be set so three or four sheets thickness is between the feed roll and the back-idler roll.

► Not folding square (Earlier models)

- A. Move both side guides back to the edge of the table.
 1. Place paper on the feed table with the leading edge squarely against the fold roller centered on the feed table.
 2. Turn the hand wheel so the rollers will hold the paper.

Helpful tips for Baumfolder Model 714

Not folding square – earlier models (continued)

3. Move one side guide to the paper and align the guide to the paper.
 4. Do the same with the other side guide so both side guides are square with the number one-fold roller.
 5. Set the hold downs at the end closest to the fold rollers the thickness of chipboard from the feed table. This will guide the paper onto the nip of the fold rolls without stumbling.
- B. Speeding up or slowing down the folder after it is set up will change the lengths of the folds.
- C. Check to make sure the plate stops are not skewed (sheet should touch both sides at the same time).
- D. Clean the rollers.
- E. Check for wear on the rollers.
- F. If you still have trouble, call your local Baum dealer.

► **Not folding square, newer models**

Square the guide with the fold rollers.

- A. Remove the number 1-fold plate (top fold plate).
- B. Take an 11 x 17 sheet of paper that is cut square and lay on feed table against one of the side guides.

Not folding square – newer models (continued)

- C. Hand feed the sheet into the folder and watch the sheet come out of the first set of rolls. Watch the sheet to see if it comes out square, or if one corner comes out before the other. If one corner comes out before the other, you know you are not feeding square.
- D. Referencing the diagram above, loosen the rear locking screws on the back of the side guide, then push in the micro-adj. knob and rotate the back of the side guide in the direction that the back of the paper needs to move to square the side guide. Once you have moved the side guide retighten the rear locking screws.
- E. Repeat step 3 to see if the paper is now coming out square. If not repeat step 4 until side guide is square.
- F. When you get the side guide square then loosen the collar and rotate it until the micro-adj. knob falls back on to it then retighten the collar.



Helpful tips for Baumfolder Model 714

- G. Then align the other side guide to the first side guide using the square sheet of paper.
- H.

▶ Marking

- A. Wet ink will cause marking problems. Allow ink to dry. Some types of ink (rubber base ink) only dries on the surface. To check, rub a printed sheet with a blank white sheet of paper. If the ink smears on the white sheet, it is this type of ink. The only solution for marking with this type of ink is to try not let anything rub the paper in the printed area, But the ink will build up on the fold rollers. You will need to clean the fold rolls often. ALWAYS disconnect the power supply when cleaning the rollers.

▶ Wrinkles

- A. Make sure the fold rollers are clean and free of ink and grooves.
- B. Make sure the side guides are not too tight against the paper.
- C. Check for static.
- D. Square the guides with the fold rollers. (See not folding square).

▶ Paralleling fold rollers

- A. Remove the feed table, slit shaft assembly and the top roll guard.
- B. Set a protractor head on 90 degrees. Check on both ends of the rollers, touching the number one, main drive, and number three rollers. The level on the protractor head should be the same on both ends.

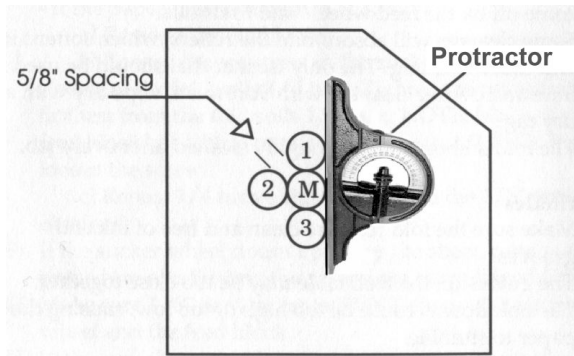

Paralleling fold rollers

(continued)

- C. Remove the fold plates. The space between the number one and two rollers should be 5/8". You can use any object 5/8" to check the gap. Adjust number two roller to obtain 5/8" by loosening the bolts for the roller block

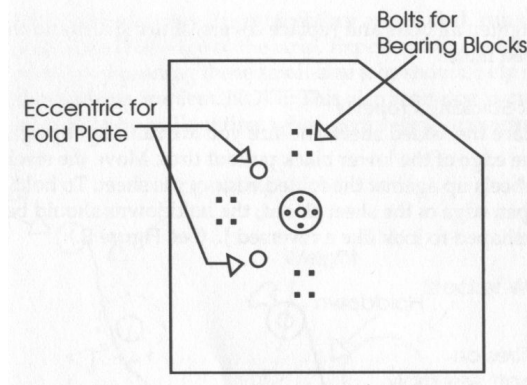

Helpful tips for Baumfolder Model 714

- D. Install the number one-fold-plate in the top position. There should be .025" between the nose of the fold plate and the number one-fold roller. If not, the front stud for the fold plate is an eccentric. Remove the side cover (watch the wires from the side cover to the folder) The pin closest to the roller has a 9/16" nut. Break the nut loose and use a straight blade screwdriver to adjust the eccentric. Tighten the nut when you get the correct setting. This adjustment is the same on both sides of the folder and both fold plates. When the repair is complete, install the side covers.

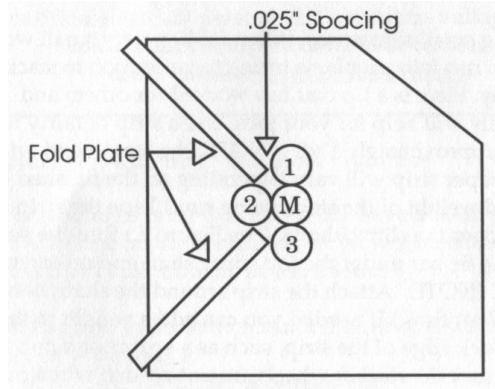

► Not stacking properly

- A. Place a folded sheet (the size you are running) up against the edge of the lower black pullout tires. Move the stacker wheels up against the folded edge of the sheet. To hold the open edge of the sheet closed, the hold-downs should be reshaped to look like a reversed J.



BAUMFOLDER
SOLUTIONS

Helpful tips for Baumfolder Model 714

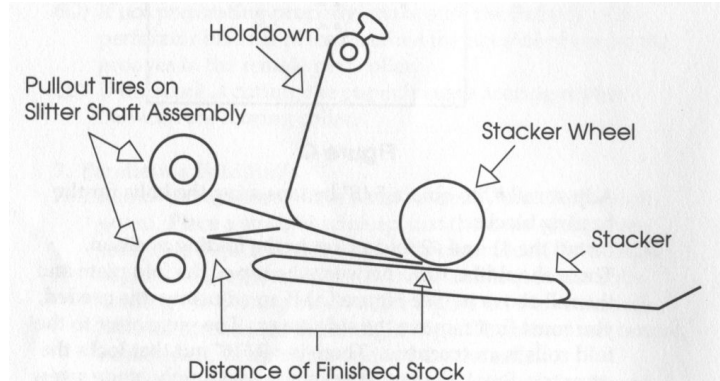

- B. Stacking small signatures: When folding very small work, you can run into problems trying to get the job to stack properly. Here is a tip that has worked for others and hopefully will help for your job. Use a strip of heavy paper, approximately 1x8". NOTE: the length and width will vary depending on the finished job size and weight of the paper being run. Tape the strip to the tie bar over the slitter shafts. Run the strip from the tie bar under the top slitter shaft and out over the bottom slitter shaft onto the stacker. You can add weight as needed by taping a bolt or nut on top of the end of the strip of paper. You can move it back and forth to add the weight where it is needed. Note: this also works is paper is stumbling on the pullover tires when perforating or scoring.

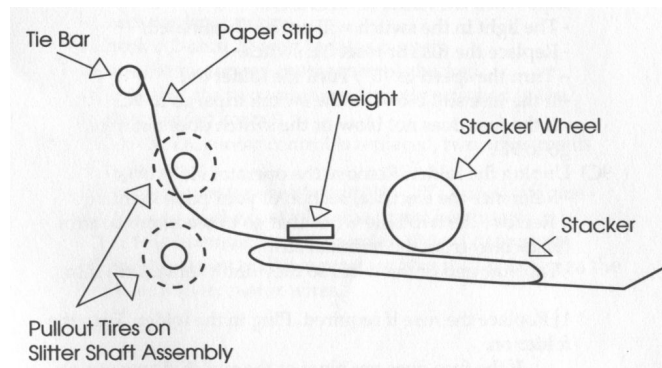

► Perforating and, or scoring

You can add a perf/score attachment that has adjustable slitter shafts. For information, call your local Baum dealer.

⇒ Scoring – setting up your folder



BAUMFOLDER
SOLUTIONS

Helpful tips for Baumfolder Model 714

The score blades are sharp. Extra care should be exercised to protect you from a cut by the score blades.

BEFORE BEGINNING: On Air Feed and 714 AUTOFOLD units, disconnect the air and vacuum hose, and on the AUTOFOLD, disconnect the electrical connection to the feed table.

(Reference pictures follow these setup instructions)

1. Lift up on the rear of the feed table and lift toward you to remove the feed table.
2. Under the feed table and just prior to the stacker is the **slitter shaft assembly**. On the left side of the slitter shaft assembly is a **screw or plunger** that tightens against the frame to remove endplay (movement from side to side). Loosen **screw or pull plunger**.
3. Carefully lift both ends up even and then towards you and lay the slitter shaft assembly on a worktable with the rubber pullout tires toward the worktable top.
4. Loosen the **socket head bolt** from the end of the tie bar that fastens the **left slitter shaft boxing** to the slitter shaft assembly. Remove the slitter shaft boxing from the slitter shafts.
5. Loosen the setscrew on the **left pullout tire assembly** and remove it from the top slitter shaft. Leave the right pullout tire assembly in place.
6. To prepare the **score blade assembly** remove the two screws from the **blade holder collar** and lay the **score blade** on the side of the **blade holder collar** and align the holes in the score blade with the blade holder collar and replace the two screws. Do not tighten them now.
7. Slide the score blade and blade holder collar onto the top slitter shaft to the center of the top slitter shaft and tighten the setscrew in the blade holder collar to lock it in position, and then tighten the two screws to insure the score blade is tight against the blade holder collar.
8. Replace the **left pullout tire assembly** on the top slitter shaft and place it approximately three inches from the score blade and tighten the setscrew to lock it in place. Keep all setscrews in line so if you need to move them, you will not have to keep turning the slitter shaft.
9. Remove the **left pullout tire assembly** from the bottom slitter shaft.
10. Slide the **score collar assembly** on to the bottom slitter shaft until the **score blade** aligns with the middle on the one-inch rubber in the **score collar assembly**. Tighten the setscrew to lock the score collar in place.
11. Slide the left pullout tire assembly directly under pullout tire on the top slitter shaft and tighten the setscrew to hold the pullout assembly in place.



BAUMFOLDER
SOLUTIONS

Helpful tips for Baumfolder Model 714

12. Replace the **left slitter shaft boxing** and tighten the socket head bolt into the tie bar
13. Replace **slitter shaft assembly** into the folder in reverse order it was removed.
14. Replace feed table in reverse order removed.
15. Turn the folder by hand to insure nothing is loose or rubbing and that everything is free.
16. Set up folder and run sheet through by hand and move perforator into position desired and lock any setscrews you may have moved. Turn another sheet through by hand, and if ok, plug in folder.
17. Turn on and run a sheet through and check fold and location. If ok run job.

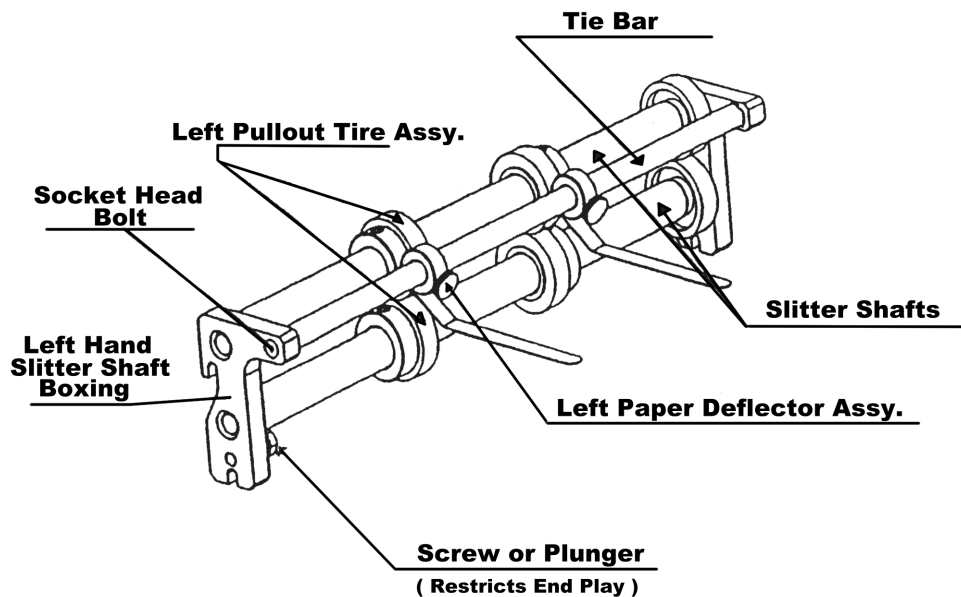

Reference
the setup to
instructions - continued

*pictures for
score*



BAUMFOLDER SOLUTIONS

Helpful tips for Baumfolder Model 714

Part Number Information

| | |
|----------------------------------|---------------|
| Left Pullout Tire Assembly..... | 06404 |
| Left Paper Deflector Assembly... | 262-453-BG-01 |

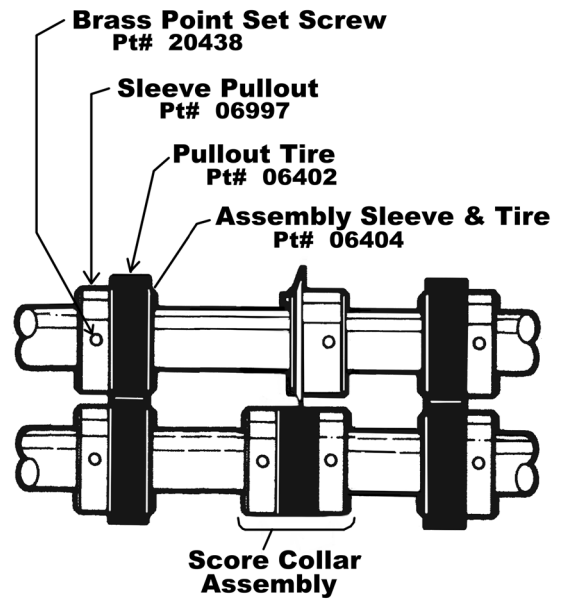
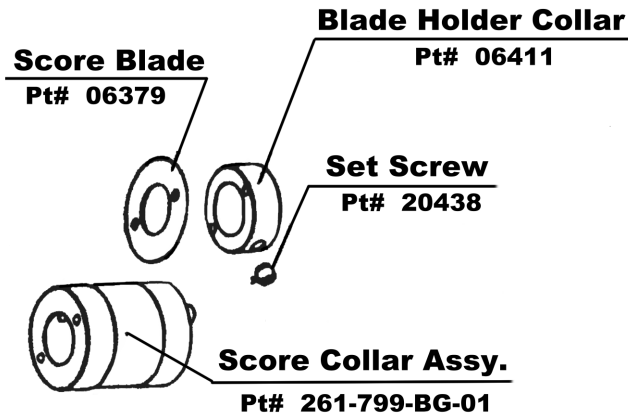

(Document continues next page)

⇒ Perforating

The perforator blade is sharp. Extra care should be exercised to protect you from a cut by the perforator blade.

** (Reference pictures follow these setup instructions)*

1. On the air feed and the 714 AUTOFOLD units, disconnect the air and vacuum hose and on the AUTOFOLD, disconnect the electrical connection to the feed table. Lift the rear of the feed table and lift it toward you to remove the feed table. Under the feed table and just prior to the stacker is the **slitter shaft assembly**. On the left side of the slitter shaft assembly is a **screw or a plunger** that tighten against the frame to remove endplay (movement from side to side). Loosen the screw or plunger. Carefully lift both ends up even and toward you and lay the slitter shaft assembly on a worktable.
2. Loosen the **socket head bolt** from the end of the **tie bar** that fastens the **left slitter shaft boxing** to the complete assembly and remove the boxing from the slitter shafts.
3. Loosen the setscrew in the **left pullout tire assembly** and remove it from the top slitter shaft. Do not remove the right pullout tire assembly.
4. To prepare the perforator blade, remove the two screws from the **blade holder collar** and lay the perforator blade onto the side of the blade holder collar and align the screw holes in the collar and replace the two screws to fasten the perforator blade to the blade holder collar. Do not tighten the screws at this point.
5. Slide the **perforator blade and the blade holder collar** to the center of the top slitter shaft and tighten the brass point set screw. Now tighten the two setscrews on the blade holder collar.
6. Replace the **left pullout tire assembly** on the top slitter shaft and place it about three inches from the perforator blade and tighten the brass point set screw to secure it to the top slitter shaft.
7. Keep all the brass point set screws in a line so if you must move any one of them later, you do not have to keep turning the shafts.
8. Install the **perforator stripper** on the **tie bar** so it comes from the front of the tie bar and down and between the perforator blade and the bottom slitter shaft. Do not tighten yet.
9. Remove the **left pullout tire assembly** from the bottom slitter shaft by loosen the brass point set screw and sliding it off the bottom slitter shaft.
10. Slide the **female perforator collar** until the wide groove of the female collar is under the perforator blade. Leave it loose for now. The **perforator stripper** should be between the perforator blade assembly and the female perforator collar.



Helpful tips for Baumfolder Model 714

11. Slide the **left pullout tire** you just removed back on the bottom slitter shaft until it is directly under the left pullout tire on the top slitter shaft and tighten the brass point set screw to secure the pullout tire assembly to the shaft.
12. Replace the **left slitter shaft boxing** on the slitter shaft in reverse order as you removed them. Install the **socket head bolt** that fastens the left slitter shaft boxing to the slitter shaft assembly and tighten it.
13. Move the **female perforator collar** until the sharp edge of the blade is against the edge of the wide groove in the female perforator collar and tighten the brass point set screw in the collar to secure it in place. The blade against the edge of the groove creates a scissors action as the shafts turn. **THE PERFORATOR BLADE IS SHARP. CAUTION SHOULD BE EXCRISED WHEN WORKING AROUND THE PERFORATOR BLADE.**
14. Replace the slitter shaft assembly in reverse order as it was removed. Extra care should be made to ensure the slitter shaft boxings are secure on all four pins in the frame and the gears all mash properly. Turn the hand wheel a couple times to ensure the slitter shaft assembly is in proper position.
15. Raise the **perforator stripper** until it is not rubbing the **blade holder** and along the side of the **perforator blade** and it will allow a sheet of paper to go under the stripper and above the female perforator collar without jamming them lock it in place. The purpose of the stripper is to strip the sheet off the perforator blade otherwise the sheet would wrap around the top slitter shaft.
16. Replace the feed table in reverse order it was removed. Again, turn the hand wheel to be sure everything is in the proper place and nothing is rubbing, run a sheet through to see if the perforator is in the proper location. If not loosen the setscrews and move the assemblies where you want them on the shafts and lock with the brass point setscrews. Turn the hand wheel to insure nothing is rubbing and check it again.

Reference pictures for the setup to perforate instructions.

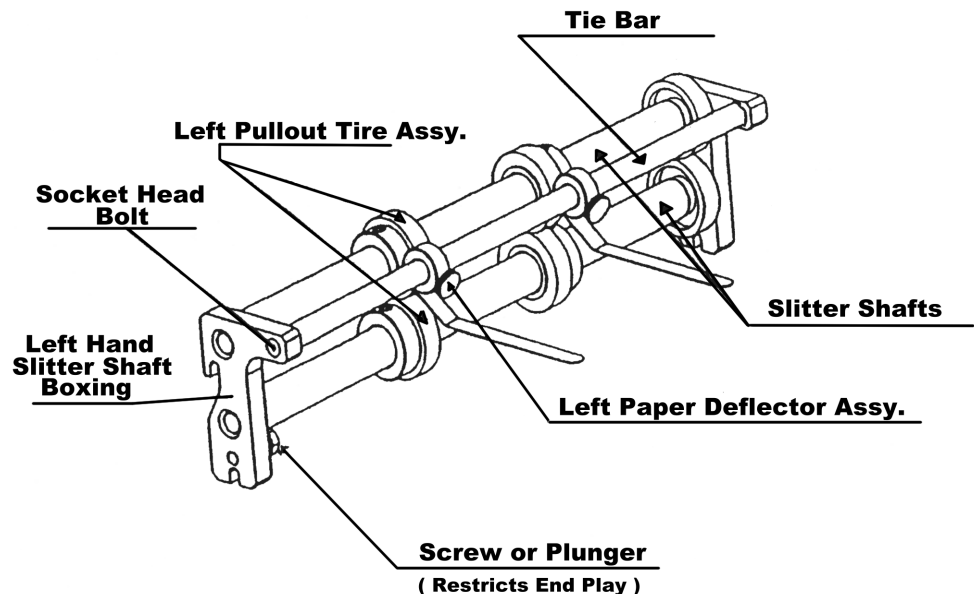



BAUMFOLDER
SOLUTIONS

Helpful tips for Baumfolder Model 714

Reference pictures for the setup to perforate instructions - continued

Part Number Information

- 1 Pullout Tire Assy. 06404
Sheet Pullout Sleeve 06997
Pullout Tire 06402
- 2 Perforator 07791
- 3 Blade holder 06411
- 4 Screw – 10-24 x 3/8 20312
- 5 Female Perforator Collar 06799
- 6 Screw Brass Point tip 20438
- 7 Perforator Stripper S45297

