

**BAUMFOLDER
CORP.**

WetScore

**INSTALLATION,
INSTRUCTION
&
PARTS
MANUAL
FOR
1300/1400
SERIES
FOLDERS**



©
BAUMFOLDER CORPORATION
All Rights Reserved

WARNING

- Do not operate this machine without all guarding in place.
- Do not make adjustments or perform maintenance on this machine with power on.
- Keep the machine and the work area clean and free of spills to prevent accidents.
- Be sure to replace any safety decals that may have been detached for any reason.

BAUMFOLDER reserves the right to make changes in design or to make additions or improvements in its products without imposing any obligation upon itself to install them on its previously manufactured products. It is recommended that modifications to this equipment not be made without the advice and express written consent of BAUMFOLDER.

FOLDER IDENTIFICATION

MODEL NO: _____ SERIAL NO: _____

SALES AGENCY: _____

INSTALLED BY: _____ DATE: _____

PHONE NO: _____

Contents

SECTION 1:

SAFETY	4
BASIC	4
ADDITIONAL NOTES	4

SECTION 2:

HOW <i>WetScore</i> WORKS	5
--	----------

SECTION 3:

SET UP	6
1.0 ALCOHOL/WATER MIXTURE	6
2.0 NUMBER of SCORES	6
3.0 BLEEDING AIR from TUBING	6
4.0 LOWERING PIVOT ROD into PLACE	7
5.0 PROPER NEEDLE for JOB	7
6.0 PLACEMENT of NEEDLES on STOCK	7
7.0 FLOW RATE ADJUSTMENT	8
8.0 PHOTO SENSOR POSITIONING	8

SECTION 4:

REFILLING BOTTLE	8
1.0 FLUID LEVEL	8
2.0 BLEEDING AIR	8
WHILE RUNNING JOB	8
1.0 FLUID LEVEL	8
2.0 NEEDLE FLOW RATE	8
3.0 PHOTO SENSOR LED INDICATOR	8
4.0 JAMMED SHEETS	8
5.0 FOLDER STOPS RUNNING	9
WHEN JOB'S FINISHED	9

SECTION 5:

OPERATING TIPS	9
1.0 <i>WetScore</i> with MECHANICAL SCORES	9
2.0 <i>WetScore</i> with PERFORATORS	9
3.0 <i>WetScore</i> ACROSS PRINTED SOLIDS	9
4.0 <i>WetScore</i> with COATED STOCK	10
5.0 SQUARE SIDE-GUIDE	10
6.0 <i>WetScore</i> with LIGHT STOCK	10

SECTION 6:

MAINTENANCE	11
--------------------------	-----------

SECTION 7:

TROUBLESHOOTING	12
------------------------------	-----------

SECTION 8:

INSTALLATION & PARTS	14
---------------------------------------	-----------



SAFETY FIRST BASIC



Your new BAUMFOLDER paper folding machines have been designed in accordance with the latest safety specifications. The warning and caution labels on the machine must remain in place. Make sure all guarding provided is in place before starting up and running the machine.

Due to the nature of the work process of paper folding machines, there are parts and areas on the machine which cannot be completely covered without interfering with the operation of the machine. Therefore, sound personal work habits and strict observance of all safety precautions is required for the protection of the operator, co-workers, and the machine.

Be certain to follow these safety precautions:

1. Study the safety instructions at your plant and those provided in this manual.
2. Study the operating instructions carefully before operating the machine.
3. Make sure that your co-workers are familiar with the work process, potential danger areas, and all necessary safety measures.
4. Make sure that the machine is in good working order before turning it on.
5. If the machine suddenly stops for whatever reason, do not restart it right away. Someone may have stopped the machine, but failed to press the emergency (Stop) button. If the machine is restarted unexpectedly, your co-worker could be seriously injured.
6. Always press the emergency (Stop) button first if you stop the machine for adjustments or maintenance work which must not be done while the machine is in operation.
7. For extensive maintenance or repair work, turn off the main power supply.
8. Never use improper or defective tools.
9. After making adjustments or after doing maintenance or repair work, always make sure that all tools and other objects are removed from the machine. Otherwise, they might fall into the machine, causing severe damage or injuries.
10. Make sure that all safety devices are in place before restarting the machine.
11. Never clean moving parts of the machine (rollers, shafts, etc.) or remove any test sheets or paper jams while the machine is running.
12. Keep the floor around the entire machine clean. Immediately clean up any oil, grease, or paint spills from the floor. Remove tools, cleaning cloths, and paper scraps from all work areas.
13. Never allow unauthorized personnel to make adjustments on the machine, remove problem sheets, or start the machine.
14. Never climb over the machine or crawl into it while it is turned on.
15. Immediately repair or replace any safety devices which have become ineffective or are missing.
16. Report any exposed cables or exposed electrical connections.
17. Always have a certified qualified electrician perform all electrical maintenance.
18. Do not make adjustments or perform maintenance with the power on.
19. Become familiar with and follow the safety labels on the next page. Replace any of these labels that are damaged or lost.

Additional Notes:

20. Do not attempt to remove a paper jam, no matter how minor it may appear to be, while the machine is running.
21. When cleaning the fold rolls, use the handwheel for turning. Be sure the power to the machine is off.
22. Turn off the machine before making any adjustments to the scoring, perforating, or slitting attachments. Keep hands and clothing away from the slitter shafts when the machine is running.

How The *WetScore* Works

The *WetScore* is designed to give you absolutely straight, tight and consistent folds out of your existing folder.

New or well used, your folder will show an improvement in performance with the addition of the *WetScore*; increased running speeds, tighter more accurate folds, less waste and a reduction of downtime.

The *WetScore* applies a fine line of an alcohol/water mixture to the sheet, breaking the grain of the stock, prior to the sheet entering the fold rollers. This eliminates the bother of getting a straight score out of the parallel section of your folder. The wet line applied to the sheet on the register table is always straight, as long as the sheet registers to the guide before reaching the *WetScore* needle applicators. For this reason the *WetScore* is installed on the folder as close to the fold rollers as possible.

The *WetScore* applies a fine line to the stock regardless of the speed at which the folder is running. By placing the needle applicators directly upon the stock, the surface tension of the fluid is overcome and the *WetScore* is able to apply the fluid to the stock by capillary action. The effective result of this action is that the faster you run the folder, the faster the flow of fluid onto the stock! For this reason *it is essential that the needles are always in contact with the surface of the stock when using the WetScore.*

The *WetScore* is the only product of its type that features an automatic shut-off to prevent build-up of fluid on the folder. The shut-off is accomplished by a signal sent from a photoelectric sensor to a control modulated amplifier. The amplifier has a built in delayed off signal that is preset at the factory for 1 second. If the *WetScore* sensor does not detect a second sheet within 1 second, the Amplifier will send a signal to the solenoid stopping the flow of fluid to the control valves. For this reason a small amount of fluid will be seen falling between sheets during the running of a job, as well as when the folder stops running.

MACHINE SAFETY

1. Needles are Sharp! Place needles in needle holders on control amp base when not in use. Use caution when handling!
2. Unplug *WetScore* when not in use.
3. Wipe up all spills.
4. Do not operate without the amp housing cover in place. No user serviceable parts inside.
5. Keep all tubing away from fold rollers. Do not operate the folder without guards in place.
6. To avoid unnecessary wear of the tubing, keep tubing from resting on the cross carrier drive rollers of the right angle unit.
7. Prolonged operation of the *WetScore* will result in the heating of the shut-off solenoid. Use caution when handling.
8. Alcohol/water solution is flammable. Keep away from excessive heat or open flame!

SET UP

1.0 THE RIGHT ALCOHOL/WATER MIXTURE

The *WetScore* uses a mixture of Isopropyl ALcohol (Commonly known as Rubbing Alcohol) and water. The alcohol serves two purposes. First, it acts as a drying agent to cause rapid evaporation of the solution from the signatures. Secondly, it insures that the fluid maintains a uniform line upon the stock. For these reasons it is important that the solution be mixed in the proper proportions. Too little alcohol in the solution and the fluid will tend to spread out upon the sheets in a ribbon rather than a fine line and the signatures will feel excessively wet. Too much alcohol and the fluid will have a difficult time absorbing into the stock and inconsistent folds will result.

As a rule of thumb, during operation of the *WetScore* the signatures should feel wet to the touch immediately after folding and dry within 3 to 5 minutes. You should be able to smell the alcohol on the signatures. The folded signatures should appear flat. If the signatures appear to be rippled along the scored and folded edge you are using too much water and we advise remixing your solution. To avoid unwanted downtime, we advise keeping a premixed container of solution nearby the folder to fill the water bottle during operation of the *WetScore*.

2.0 DETERMINE THE NUMBER OF SCORES

In most cases you will want to use the *WetScore* when you are folding in the 8 page (right angle). We recommend using the *WetScore* not only for those situations in which you would normally use a mechanical score, but for folding with perforators as well. The *WetScore* is not meant to replace the perforators, but operates in addition to them. The resulting signatures will be flatter, usually eliminating dog-ears and assuring you straight perforations.

3.0 BLEEDING AIR FROM THE TUBING

The Greatest factor in insuring a strong flow of fluid through the WetScore is the absence of air in the tubing that runs from the bottle to the control valves.

A. BLEEDING THE TUBING FROM THE ON/OFF SOLENOID TO THE CONTROL VALVES

1. Plug the *WetScore* into a 110V. outlet.
2. Make sure that the LED indicator light on the photoelectronic sensor is not lit, indicating that the solenoid is closed.
3. Close all of the control valves.
4. Remove the rubber cap from the end port of the control valves.
5. Place a rag over the open port to catch fluid when the solenoid is opened.
6. Place your free hand under the sensor to open the solenoid.
7. Allow fluid to run through the system until no air is visible in the tubing between the solenoid and the control valves.
8. Remove your hand from under the sensor, when the flow of fluid stops, replace the cap on the open port.

B. BLEEDING THE TUBING FROM THE CONTROL VALVES TO THE NEEDLES

1. Remove needles from the nozzles.
2. To avoid spilling the fluid upon the folder, it is recommended that you remove the nozzles from their holders.
3. Hold the nozzles away from the folder and point them into a pail or absorbent rag to catch the fluid when it leaves the nozzle.
4. Open the appropriate control valves.
5. Hold your hand under the sensor to open the on/off solenoid.
6. Bleed the tubing until the fluid flows consistently from the nozzle.
7. It is customary for some air to remain in the tubing after bleeding. This will usually not affect the flow.

4.0 LOWERING THE PARALLEL UNIT PIVOT ROD INTO PLACE

- A. Make sure that the needles are not in the nozzles.
- B. Lower the rod slowly to ensure that the nozzle holders as well as the sensor do not sit upon the shoe-in guides, register table sheet holddowns, or side guide.
- C. Snap rod into place on the support bracket.

5. THE PROPER NEEDLE FOR THE JOB

The *WetScore* is installed with 23 guage needles. We have found that for most of the work that comes through the shop these are sufficient. However, for heavy stock; 80 lb. or greater; you may wish to use a bigger needle. Make sure that the needles are not bent. Secure the needles in the nozzles. The nozzles are internally threaded to fit the needles, no tools are necessary. Insert the needles into the nozzles and hand tighten, do not over tighten.

6. PLACEMENT OF THE NEEDLES UPON THE STOCK

A. POSITIONING OF THE NEEDLES IN RELATION TO THE REGISTER TABLE AND TAPE DRIVE ROLLER.

Adjustment is made by sliding the nozzle (needle attached) in and out of the nozzle holder.

1. The ideal location of the end of the needle is between the register roller and the plate of the register table so that any drips from the needles will fall to the floor and not build up on the register table.
2. Secure the needle nozzle in position within the nozzle holder by means of the nylon set screw on the side of the nozzle holder.

B. POSITIONING OF THE NEEDLE IN RELATION TO THE PAPER STOCK

Adjustment is made by rotating the nozzle holder about the pivot rod to the proper position on the stock.

1. With the pivot rod down, run a sheet to be scored under the rod until the registermark for the folder(or a premarked scoring mark) is under the rod.
2. Slide the nozzle holder with the needle in place along the rod until it is over your mark.
3. Rotate the nozzle holder down until the needle lies on top of the mark and secure it in position by tightening the nylon set screw on the top of the nozzle holder. Hand tighten only.
4. When the needle is in the proper position it should be touching the stock, with a slight downward pressure. Do not lower it too far however as it will retard the motion of the stock.

7.0 ADJUSTMENT OF FLOW RATE

- A. With the folder off, place your hand under the sensor and open the appropriate control valve.
- B. Watch for air bubbles in the tubing to move indicating flow from the needles.
- C. Adjust control valves until the flow is greater than 2 drops per second from the needles.
- D. If the proper flow cannot be obtained see *TROUBLE SHOOTING* section of the manual.

8.0 POSITIONING OF PHOTOELECTRIC SENSOR

- A. The sensor is of the photoreflective type, it does not require a "hole" under it to see through. Simply position it over the sheet so that it does not interfere with the side guide, shoe-ins, nozzle holders, etc.
- B. Run one sheet under the sensor and watch to see if the LED light on the sensor is lit when the sheet is present, and off when not.
- C. Adjust by rotating as necessary.

REFILLING THE BOTTLE

1.0 FLUID LEVEL OF THE BOTTLE

When refilling the alcohol/water solution in the bottle, it is recommended that the bottle be only filled to 90% of capacity.

2.0 BLEEDING AIR FROM THE TUBING

When filling the bottle, always bleed the tubing between the on/off solenoid and the control valves. Air may become trapped in the solenoid and an inconsistent flow will result if not removed.

It is usually not necessary to bleed the tubing to the needles if there is adequate flow between the solenoid and the control valves. For procedure see instructions above.

WHILE RUNNING A JOB WITH

WetScore

1.0 CHECK THE FLUID LEVEL OF THE BOTTLE

Never let the bottle run dry, unwanted air will fill the lines. If the flow is sluggish, or signatures feel dry, fill the bottle, the flow is gravity fed and dependent upon pressure from the bottle.

2.0 WATCH THE FLOW RATE OF THE NEEDLES UPON THE STOCK

When the needle is on the sheet and the folder is running, the line of fluid laid down by the *WetScore* should approximate the size of the needle used. Check to be sure that the needle is in constant contact with the sheet.

Do not allow space between the sheet and the needle. The *WetScore* uses capillary action to pull the fluid out of the needle by the motion of the stock underneath it. If the needle is allowed to pour fluid upon the sheet, it will become difficult to obtain a consistent flow and uniform score along the sheet.

When the folder is running and the sheet gap is under the needle, a drop of fluid should be visible at the end of the needle prior to the next sheet running under the needle. A strong flow may be desirable for heavy uncoated stock.

Signatures should feel slightly wet to the touch along the scored edge.

3.0 CHECK THE LED INDICATOR ON THE PHOTOELECTRIC SENSOR

While the folder is running, the LED indicator light on the photoelectric sensor should be off when there is no sheet under the sensor. The indicator should blink on and off with the sheet. If it is constantly on, raise the sensor slightly to ensure that the solenoid will shut off when the folder stops running.

4.0 REMOVING JAMMED SHEETS

NEVER PULL SHEETS OUT OF THE FOLDER WHEN THE NEEDLES ARE IN CONTACT WITH THE SHEET. NEEDLES MAY BEND AND YOU WILL LOSE YOUR SHEET REGISTER!

When running sheets through the folder by hand, if it becomes necessary to back the sheet out, always lift the rod to ensure that the sheets do not jam into the needles. They may cause the needles to bend and you will lose your register!

If a sheet is under a needle or the sensor when the folder stops, remove it before restarting the folder. It may be wet and may cause a jam-up in the rollers.

5.0 WHEN THE FOLDER STOPS RUNNING

- A. Remove the sheets from under the sensor and needles so that the needles do not flow.
- B. If the folder will be off longer than 10 minutes:
 - 1. Turn off the control valves to prevent air from entering the tubing.
 - 2. Unplug the electrical cord (optional).
- C. If the folder will be off less than 10 mins., no need to shut off the control valves.

NEEDLES WILL CONTINUE TO DRIP DUE TO PRESSURE IN THE TUBING FOR SEVERAL SECONDS AFTER THE ON/OFF SOLENOID CLOSSES.

WHEN YOU FINISH A JOB

- A. Remove needles and place them in the holes on the Amplifier housing support base for safety.
- B. Unplug the *WetScore*.
- C. Raise the pivot rod and secure it in the upright position by use of the Velcro strap on the hanger rod
- D. Close all of the control valves.
- E. The water bottle may hang full from its hanger until needed for the next job.

OPERATING TIPS

1.0 *WetScore* IN COMBINATION WITH A MECHANICAL SCORE

Due to the variable nature of the many types of stock operators are forced to deal with these days, there is no rule as to when to use a combination of mechanical scoring and *WetScore*. We have found however, that for certain heavy sheets, as well as cover stock, that the combination of the *WetScore* with a mechanical score in the pull-out rollers of the folder produces exceptional results. This is especially true when using the *WetScore* to apply a score to the last fold of a 16pg. signature. Many times the use of a mechanical score alone produces cracking or tearing of the signatures along the folded edge of the sheet. The addition of the water/alcohol line from the *WetScore* should eliminate this problem.

2.0 *WetScore* IN COMBINATION WITH PERFORATORS.

In many cases when folding 16 pg. or 32 pg. signatures for the perfect-binder, case binding, or other subsequent operations, it is desirable for the folded signatures to be as flat as possible. Bundling devices are commonly used to flatten the signatures after folding. We have found that the use of the *WetScore*, in addition to the perforators used for folding, produces signatures that are absolutely flat, usually eliminating the need for bundling. Additionally the *WetScore* greatly reduces the common problem of dogeared corners when used in this way. The *WetScore* is not meant to be a replacement for the use of perforations, rather an aide to their effective use.

3.0 *WetScore* ACROSS PRINTED SOLIDS OR ALONG “BLEEDS”

Use caution when applying a *WetScore* wetted line across bleeds or printed solids (i.e. reflex blue ink). The interaction of the alcohol with the ink may cause the ink vehicle to break down, producing offsetting along the folded edge. This is especially common when running coated or varnished stock. If possible, we recommend applying the *WetScore* upon the opposite side of the sheet from any bleeds or solids. Many times this can be accomplished by changing the configuration of the folder set-up, i.e. by running the job down in the second plate as opposed to up in the first plate.

Additionally, applying a solution that contains less alcohol will usually aide in preventing offsetting of the ink. However, as the solution decreases in alcohol strength, its ability to maintain a uniform line on the sheet also decreases.

The flow of fluid may also be adjusted by the control valves to apply a minimum of solution to the stock.

If you do not succeed in reducing the offset by any of the above means, we recommend that you do not use the **WetScore**, proceed with conventional mechanical scoring of the sheet.

4.0 WetScore WITH COATED STOCK

The ability of the alcohol/water solution to absorb into the sheet decreases with an increase in density of the sheet coating. Hence the effectiveness of the **WetScore** decreases as the sheet coating increases. The **WetScore** system is designed primarily for uncoated work. We have found that when used on coated sheets, the **WetScore** may prove helpful in reducing the “cracking” that commonly occurs along the folded edge of the signatures. Careful attention to the flow rate of the needles when running coated sheets is advised.

5.0 IMPORTANCE OF HAVING A SQUARE SIDE-GUIDE

One of the primary advantages of using the **WetScore** is it's capable of giving you absolutely straight scores that are applied to the sheet prior to the sheet entering the fold rollers. For this reason *it is absolutely essential that the register side-guide to be square to the fold rollers.*

6.0 WetScore ON VERY LIGHT SHEETS

For very light sheets, we recommend that the flow rate of the needles be adjusted to a minimum. If the score obtained is still not fine enough, we suggest using a smaller diameter needle.

MAINTENANCE

WEEKLY

1. Bleed all needle tubing.
2. Using an air compressor, blow out any solids that may have become trapped in the needles, i.e.-offset powder, paper particles etc. (remove needles from nozzles first).

MONTHLY

1. Tighten all support bolts on the brackets connecting the **WetScore** to the folder rails, some loosening may occur due to folder vibration. Bolts should be snug with a wrench, do not overtighten.
2. Check for sharply bent or highly worn needles replace if necessary.

YEARLY

1. Replace all PVC tubing that seems brittle or abnormally hard.
 - A. Use caution when removing the tubing from the control valve ports as the tubing through use will become slightly bonded to the brass. It is recommended that you use an Exacto knife or sharp blade to cut the tubing away from the port. Do not attempt to pull the tubing off of the port, damage to the control valves may result.
 - B. Always replace tubing with the appropriate type.
2. Check for leaks in the control valves. Replace if needed.

TROUBLESHOOTING

PROBLEM	PROBABLE CAUSE	WHAT TO DO
Poor or no flow from needles	Sensor LED is lit when holding your hand under it:	
	1. No water in the bottle	Fill bottle with solution
	2. Excessive air in the tubing	Bleed air from tubing
	3. Tip of the needle is excessively worn	Replace
	4. Control valve is closed	Open
	5. Needle is not in contact with the sheet	Adjust
	6. Solids trapped in needles	Remove the needles from the nozzles and blow out the needles with an air compressor
	Sensor LED not lit when holding your hand under it:	
	1. <i>WetScore</i> unplugged	Plug in outlet
	2. Malfunction in Modulated Amp.	Contact your dealer Rep.
Solution leaks at needle/nozzle connection		
	1. Needle is cracked	Replace
	2. Needle is not securely fastened to nozzle	Tighten
Sheet is excessively wet, score not a fine line		
	1. Flow rate is to great	Adjust control valve for proper flow
	2. Needle is to large for light	Change to smaller guage needle weight sheet
	3. To much water in solution greater amount of alcohol	Remix solution using
	4. Coating of sheet is to great for <i>WetScore</i> use	Recommend use of mechanical scoring

TROUBLESHOOTING

PROBLEM

PROBABLE CAUSE

WHAT TO DO

Build up of fluid upon register table

1. Improper setting of nozzle within nozzle holder

Readjust nozzle between register tape drive roller and register table

Inconsistent Folds

1. Positioning of *WetScore* needles is out of register

Readjust to proper position

2. Poor or no flow from needles

See above

3. Folder plate stop set off of proper position

Readjust to proper position

4. Alignment *ofWetScore* needle to mechanical score is improper

Realign the *WetScore* needle to the mechanical score

Ink is offsetting along the folded edge

1. Sheet coating is too dense for absorption of alcohol solution, alcohol is breaking down the ink

Use of *WetScore* is not recommended

Solution leaks from control valve port

1. PVC tubing hardened and brittle

Replace, see instructions

2. Control valve has cracked

Replace

Needles do not shut off

1. Sensor is set to low

Adjust sensor so that the LED light is off when sheet is absent

Discoloration of signatures along scored edge

1. Paper stock is highly alkaline (acid free paper)

Reduce the amount of alcohol in solution to approx. 30%

1300 SERIES INSTALLATION INSTRUCTIONS

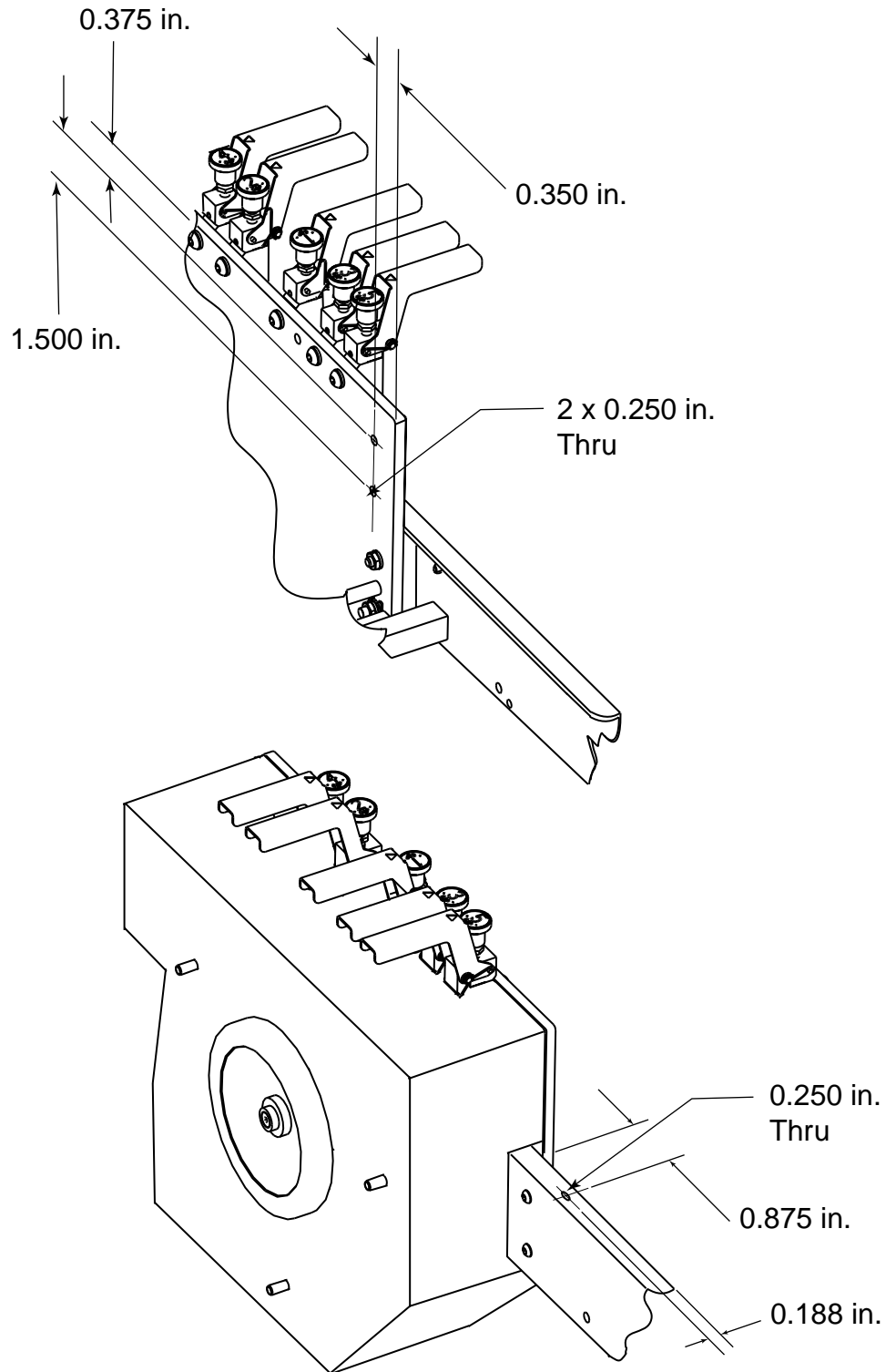

1300 SERIES INSTALLATION INSTRUCTIONS

- 2 - M6x30 BHD Screws
- 2 - M6 Fender Washers
- 2 - M6 Flat Washers
- 2 - M6 Lock Nuts

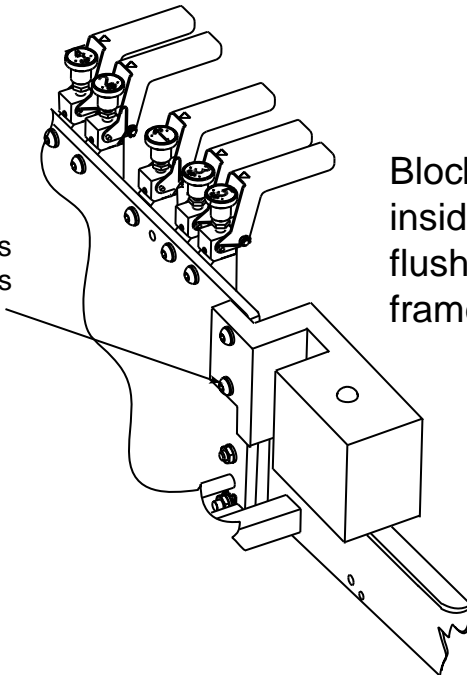

Block mounts to the inside surface of the frame flush with the top of the frame.

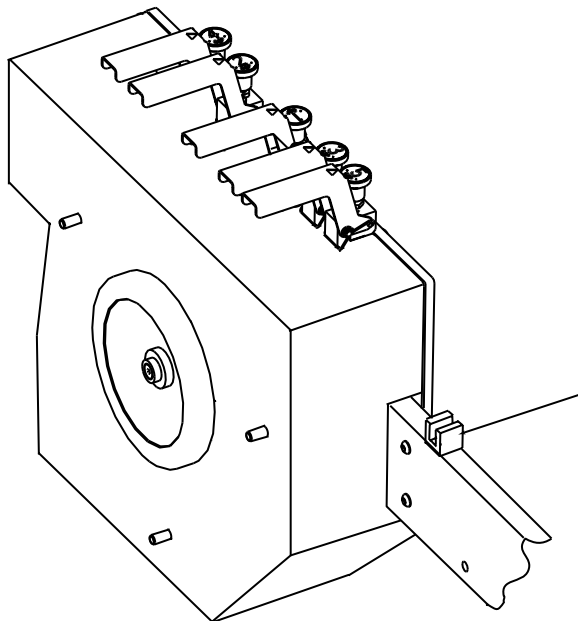

- 1 - M6x30 BHD Screw
- 1 - Clamp
- 1 - Spacer
- 1 - M6 Flat Washer
- 1 - M6 Lock Nut

1400 SERIES INSTALLATION INSTRUCTIONS

OPERATOR'S SIDE

(inside frame view, not to scale)

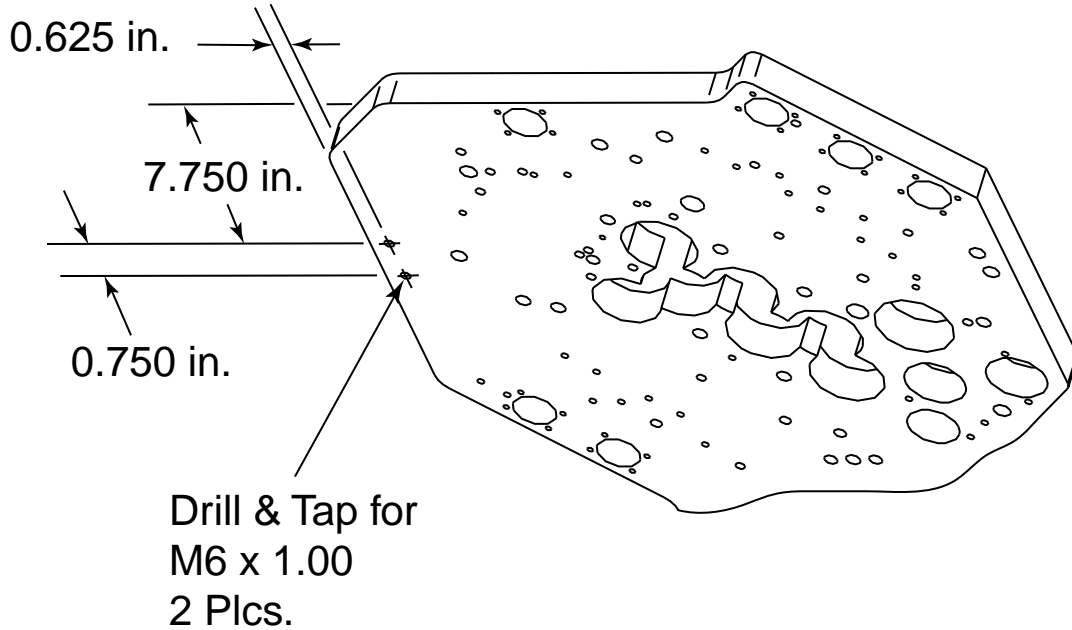

NON-OPERATOR'S SIDE

(inside frame view, not to scale)

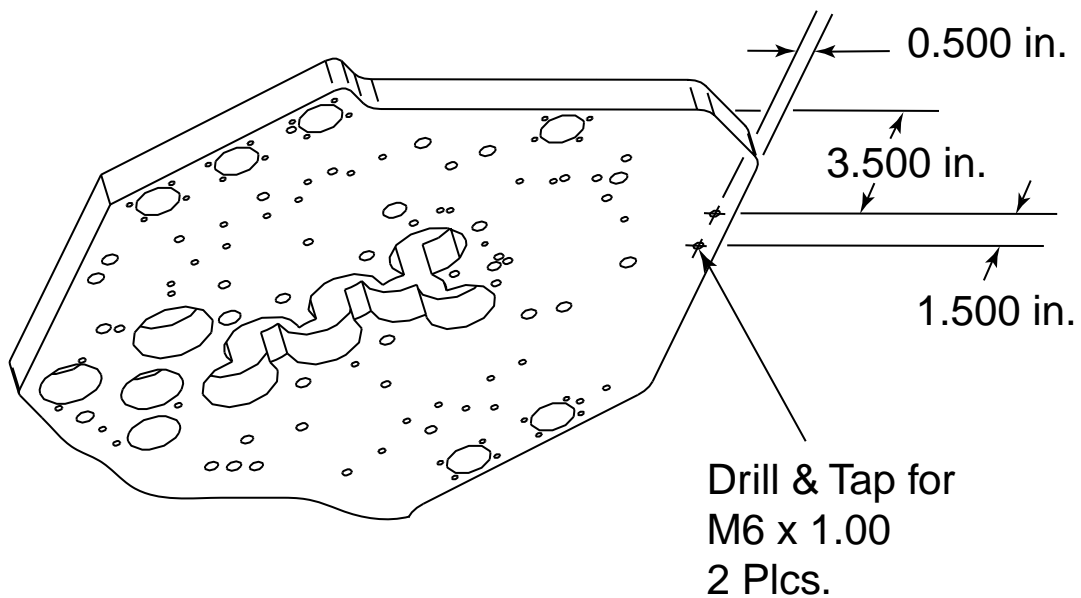

1400 SERIES INSTALLATION INSTRUCTIONS

OPERATOR'S SIDE
(inside frame view, not to scale)

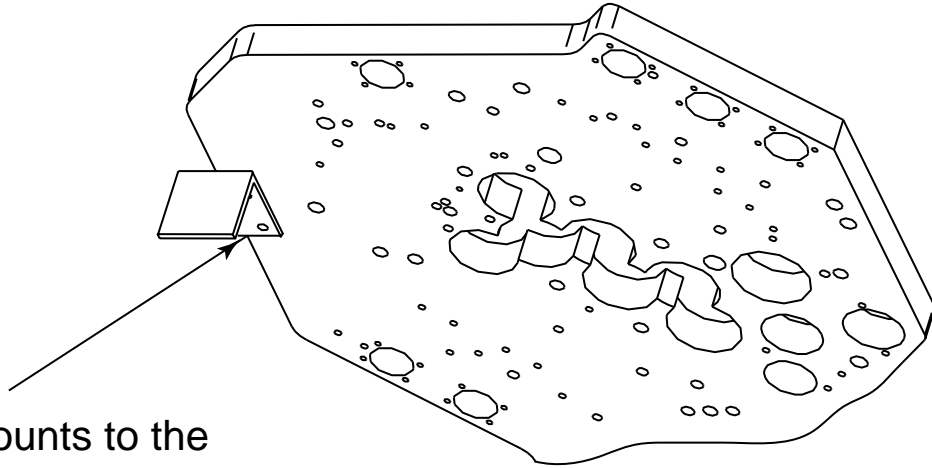

Bracket mounts to the
inside surface of the frame.

NON-OPERATOR'S SIDE
(inside frame view, not to scale)

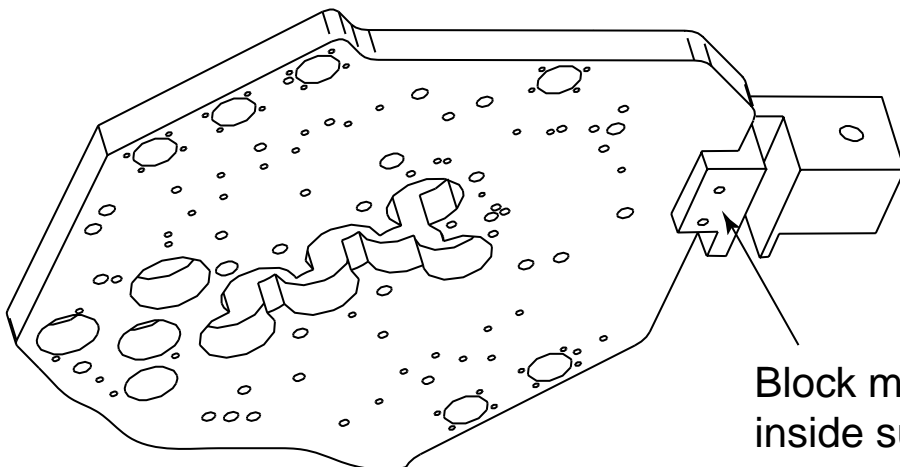

Block mounts to the
inside surface of the frame.

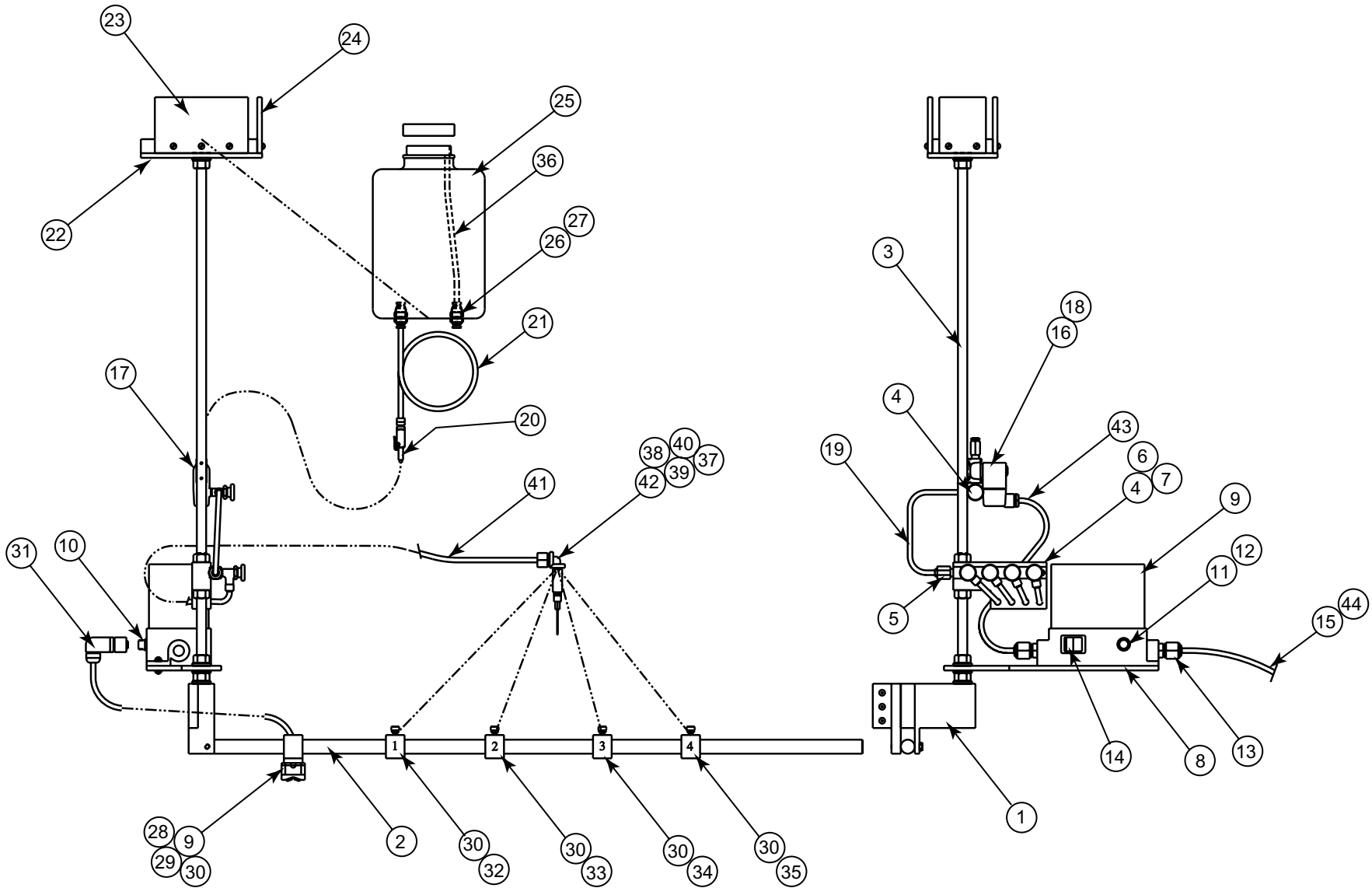

DESCRIPTION: **WETSCORE ASSEMBLY**
UNIT NAME: **WETSCORE**

ASSEMBLY NUMBER: **267-861-BG-01**

REV:
SHEET 1 OF 2

267-861-BG-01

ITEMNO.	DESCRIPTION	PARTNO.	QTY.
1	PJ604-06 MOUNTING BRACKET	268-096-01-00	1
2	PJ604-42 INJECTOR SUPPORT ARM	268-097-01-00	1
3	PJ604-07 FLUID CONTAINER SUPPORT	268-098-01-00	1
4	PJ604-10 NEEDLE VALVE	268-099-01-00	5
5	PJ604-30 STRAIGHT TUBE FITTING	268-100-01-00	1
6	PJ604-09 MANIFOLD	268-101-01-00	1
7	PJ604-11 MANIFOLD BRACKET	268-102-01-00	1
8	PJ604-12 SENSOR AMP. MOUNTING BRACKET	268-103-01-00	1
9	PJ604-17 SENSOR AMP. MODULE	268-104-01-00	1
10	PJ604-26 MALE 3 POLE RECEPTACLE	268-105-01-00	1
11	PJ604-28 FUSE	268-106-01-00	1
12	PJ604-24 FUSE HOLDER	268-107-01-00	1
13	PJ604-22 T & B CABLE STRAIN RELEIF	268-108-01-00	2
14	PJ604-23 ROCKER SWITCH	268-109-01-00	1
15	PJ604-21 ELECTRIC PLUG	268-110-01-00	1
16	PJ604-08 SOLENOID VALVE	268-111-01-00	1
17	PJ604-33 1/8 NPT STREET ELBOW	268-112-01-00	1
18	PJ604-37 VALVE MTG BRACKET	268-113-01-00	1
19	PJ604-32 VINYL TUBING 10 in. Lg.	268-114-01-00	1
20	PJ604-27 QUICK DISCONNECT	268-115-01-00	1
21	PJ604-32 VINYL TUBING 24 in. Lg.	268-116-01-00	1
22	PJ604-13 CONTAINER SUPPORT	268-117-01-00	1
23	PJ604-15 CONTAINER RETAINER	268-118-01-00	2
24	PJ604-14 CONTAINER RETAINER	268-119-01-00	1
25	PJ604-20 POLYETHYLENE BOTTLE	268-120-01-00	1
26	PJ604-31 BULKHEAD FITTING	268-121-01-00	2
27	PJ604-40 SEAL WASHER	268-122-01-00	2
28	PJ604-03 SENSOR MOUNTING BLOCK	268-123-01-00	1
29	PJ604-04 SENSOR MOUNTING BAR	268-124-01-00	1
30	PJ604-16 NYLON THUMB SCREW	268-125-01-00	9
31	PJ604-25 3 POLE 90° CONNECTOR	268-126-01-00	1
32	PJ604-02-1 NOOZLE HOLDER	268-127-01-00	1
33	PJ604-02-2 NOOZLE HOLDER	268-128-01-00	1
34	PJ604-02-3 NOOZLE HOLDER	268-129-01-00	1
35	PJ604-02-4 NOOZLE HOLDER	268-130-01-00	1
36	PJ604-32 VINYL TUBING 9 in. Lg.	268-131-01-00	1
37	PJ604-01 PIPE TO LEUR THREAD ADAPTER	268-132-01-00	4
38	PJ604-29 90° ELBOW	268-133-01-00	4
39	PJ604-18 LEUR ADAPTER	268-134-01-00	4
40	PJ604-41 FIBER WASHER	268-135-01-00	4
41	PJ604-32 VINYL TUBING 60 in. Lg.	268-136-01-00	4
42	PJ604-19 HYPODERMIC NEEDLE	268-137-01-00	4
43	TYPE SJ 16/3 ELECTRIC CABLE 2 ft. Lg.	268-138-01-00	1
44	TYPE SJ 16/3 ELECTRIC CABLE 10 ft. Lg.	268-139-01-00	1

REV: _____
SHEET 2 OF 2

ASSEMBLY NUMBER: **267-861-BG-01**

DESCRIPTION: _____
UNIT NAME: _____
WETSORE ASSEMBLY
WETSORE

