

BAUMFOLDER  
CORPORATION  
Quality Bindery Equipment Since 1917



# 714XLT AIR FEED FOLDER

INSTALLATION, OPERATION,  
MAINTENANCE & PARTS MANUAL

© 2001  
All Rights Reserved

**WARNING**

- Do not operate this machine without all guarding in place.
- Do not make adjustments or perform maintenance on this machine with power on.
- Keep the machine and the work area clean and free of spills to prevent accidents.
- Be sure to replace any safety decals that may have been detached for any reason.

BAUMFOLDER reserves the right to make changes in design or to make additions or improvements in its products without imposing any obligation upon itself to install them on its products previously manufactured. It is recommended that modifications to this equipment not be made without the advice and express written consent of BAUMFOLDER.

**FOLDER IDENTIFICATION**

MODEL NO: \_\_\_\_\_ SERIAL NO: \_\_\_\_\_

DEALER : \_\_\_\_\_

INSTALLED BY: \_\_\_\_\_ DATE: \_\_\_\_\_

PHONE NO: \_\_\_\_\_

# Contents

<b>1.0 INTRODUCTION</b> .....	<b>4</b>
<b>2.0 SPECIFICATIONS</b> .....	<b>4</b>
<b>3.0 INSTALLATION</b> .....	<b>4</b>
3.1 Unpacking & Inspection .....	4
<b>4.0 ASSEMBLY</b> .....	<b>5</b>
4.1 Main Unit .....	5
4.2 Pump Electrical Connections .....	5
4.3 Pump Hose Connections .....	5
4.4 Slitter Shaft Installation .....	5
4.5 Delivery Table .....	6
4.6 Feed Table Assembly Installation .....	6
4.7 Fold Plate Installation .....	7
<b>5.0 ELECTRICAL ACCESS</b> .....	<b>7</b>
<b>6.0 FEED TABLE SETUP</b> .....	<b>7</b>
6.1 Setting the Controls .....	7
6.2 Paper Size and Type of Fold .....	7
6.3 Paper Stop Adjustment .....	8
6.4 Gap Adjustment .....	8
6.5 Feed Table Adjustment .....	9
6.6 Air Blow Adjustment .....	9
<b>7.0 OPERATION</b> .....	<b>9</b>
7.1 Loading of Feed Table .....	9
7.2 Starting the Vacuum/Air Feeder .....	9
7.3 Check Squareness of Fold .....	10
7.4 Use of Handwheel .....	10
<b>8.0 PERFORATING, SCORING &amp; SLITTING</b> .....	<b>10</b>
8.1 Perforating .....	10
8.2 Scoring .....	11
8.3 Slitting .....	11
<b>9.0 MAINTENANCE</b> .....	<b>12</b>
9.1 Maintenance and Care of Autofold .....	12
9.2 Lubrication .....	12
9.3 Cleaning of Fold Rolls .....	12
9.4 Cleaning Filters .....	12
9.5 Photo Eyes .....	12
9.6 Cleaning The Fold Stop Guides .....	12
9.7 Replacement Parts .....	12
<b>10.0 MATERIAL SAFETY DATA SHEET</b> .....	<b>13</b>
<b>11.0 SPARE PARTS, SCHEMATICS &amp; WARNING LABELS</b> .....	<b>14</b>

# 1.0 INTRODUCTION

Your new 714XLT Air Feed Table Top Folder has been designed to give you many years of useful service provided it is installed, maintained, and operated according to the instructions in this manual.

Your 714XLT Air Feed is a unique and versatile paper folding machine, capable of folding paper measuring between 3 x 5 inches (7.6 x 12.7 cm) and 14 x 20 inches (35.5 x 50.8 cm), at speeds up to 35,000 sheets per hour of 8 1/2 x 11 (21.6 x 27.9 cm) and up to 65,000 sheets per hour of 3x5 (7.6x12.7 cm). The XLT will make six types of folds: single fold, letter fold, fan fold, French fold, double-parallel fold and a double letter fold, with a few simple settings. (Note: The French fold and double-letter fold requires either two passes or the use of a right-angle unit).

Your 714XLT is built rigid enough to ensure years of trouble-free performance, and at the same time, is compact enough to fit on any table or desk. It is portable so it can be moved anywhere it is needed.

---

## 2.0 SPECIFICATIONS

Model No.....	714XLT
Minimum Sheet Size .....	3 x 5" (7.6 x 12.7 cm)
Maximum Sheet Size .....	14 x 20" (35.5 x 50.8 cm)
Minimum Size Fold .....	2 1/4" (5.7 cm)
Maximum Paper Weight .....	65 lb. Cover
Stack Height .....	2" (5.1 cm)
Fold Roll Speed .....	Infinitely variable between 0"/min. and 7200"/min. (18,288 cm/min. or 182 m/min.)
Fold Plate Depth .....	#1 Plate, 13.5" (34.3 cm) #2 Plate, 13.5" (34.3 cm)
Fold Roll Width .....	14 1/8" (35.8 cm)
Fold Roll Diameter .....	1 1/2" (3.8 cm)
Overall Physical Dimensions .....	Height 26" (66 cm) Length 34" (88 cm) Width 23 1/2" (60 cm)
Operating Voltage .....	DOM. 110 VAC/1PH/60Hz EXP. 220 VAC/1PH/60Hz
Power Consumption (folder) .....	250 Watts
Power Consumption (pump) .....	1500 Watts
Amperage (pump) .....	DOM. 13.6 Amp EXP. 6.8 Amp

## 3.0 INSTALLATION

### 3.1 Unpacking & Inspection

The 714XLT Air Feed is packaged in three cartons, crated together as one package. It is broken down into 12 major assemblies for shipment. These are:

- A) Main Folder Assembly
- B) Pump Assembly
- C) Feed Table Assembly (not shown)
- D) Slitter Shaft Assembly
- E) Stacker Wheel Assembly
- F) Accessory Package (not shown)
- G) Fold Roll Guards (2)
- H) Stacker Tray
- I) Fold Pans (2)
- J) Hose Assembly (2)
- K) Literature Package (not shown)
- L) 1/2 Pint Surewash (not shown)

---

### NOTICE

Immediately upon unpacking, carefully inspect each of the above assemblies for shipping damage. If any damage is found, be sure to contact the delivery freight carrier to file a damage claim. Save all packaging material for the claims adjuster to inspect.

## WARNING

Do not plug the power cord into an AC outlet until the 714XLT Air Feed is fully assembled, adjusted and ready to use. Unplug the 714XLT any time disassembly is required.

## 4.0 ASSEMBLY

### 4.1 Main Unit

To assemble the 714XLT Air Feed unit, first remove the four bolts holding it to the skid. Place the folder on the stand (See Figure 4.1-1).



Figure 4.1-1

### 4.2 Pump Electrical Connections

The pump has a plug/cord set attached. This plug fits directly into the rear of the lefthand side cover. (See Figure 4.2-1)

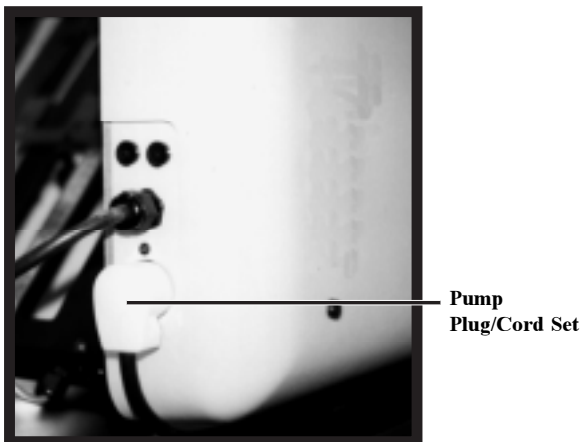

Figure 4.2-1

### 4.3 Pump Hose Connections

Two hoses come with your 714XLT Air Feed. (See Figure 4.3-1)

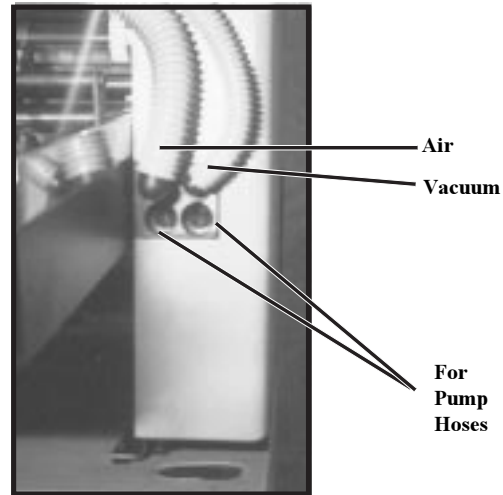

Figure 4.3-1

### 4.4 Slitter Shaft Installation

To install the slitter shaft, hold it with the grooves in the boxings down. Be sure the slitter shafts are free turning.

Insert the slitter shaft and seat the grooves in the boxings on the lower locating pins in the side frames. (See Figure 4.4-1)

Check for proper gear engagement between the upper slitter shaft gear and the 19-tooth frame idler gear by turning the handwheel.

Slitter Shaft Assembly

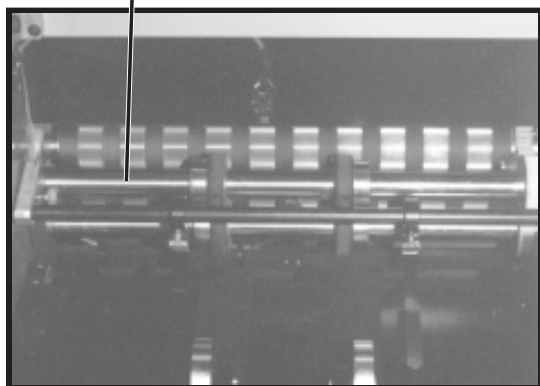

## 4.5 Delivery Table

To install the delivery table, loosen the knobs on either side of the stacker table. Drop the tray over the knobs and retighten.

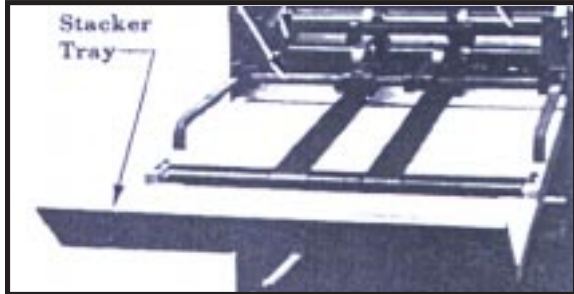

**Figure 4.5-1**

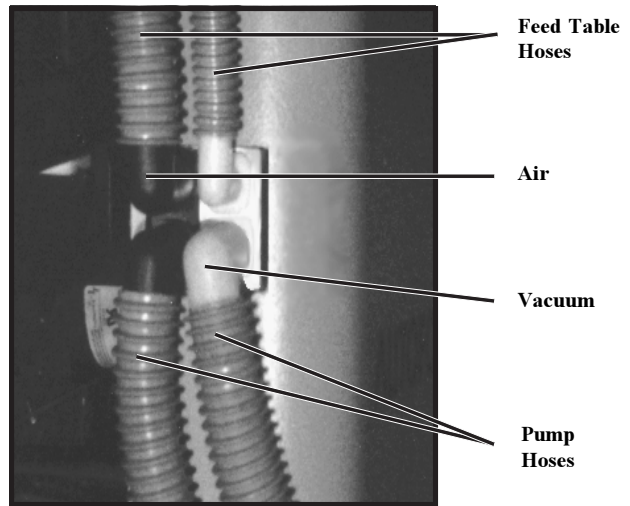

**Figure 4.6-2**

## 4.6 Feed Table Assembly Installation

Insert the feed table with the feed wheel toward the fold rolls. Slide the paper feed table over both sets of locating pins. (See Figure 4.6-1)



**Figure 4.6-1**

The first notch in the front part of the feed table should rest on the pins. Then drop the rear notch down on the upper dowel pins.

Rotate the handwheel to check that the gears are properly meshed.

Connect the feed table hoses. Push the fittings into the holes in the manifold block. (See Figure 4.6-2)

## 4.7 Fold Plate Installation

### WARNING

Unplug the AC power cord when installing or removing fold plates.

The fold plates are marked #1 and #2 and are not interchangeable. The #1 fold plate is installed in the top position, the #2 fold plate in the lower position.

Each fold plate has an open end which faces toward the fold rolls.

To install the fold plates, pivot the fold plate hold-downs out of the way and slide the fold plate in position so that the slots in the leading edge of the fold plate engage the two locating pins in the side frames. (See Figure 4.7-1)

The center notches should seat on the second set of locating pins. Pivot the fold plate hold-downs back into position to secure the fold plates.

Turn the handwheel to be sure that the fold plates are properly installed and not rubbing on the fold rolls.

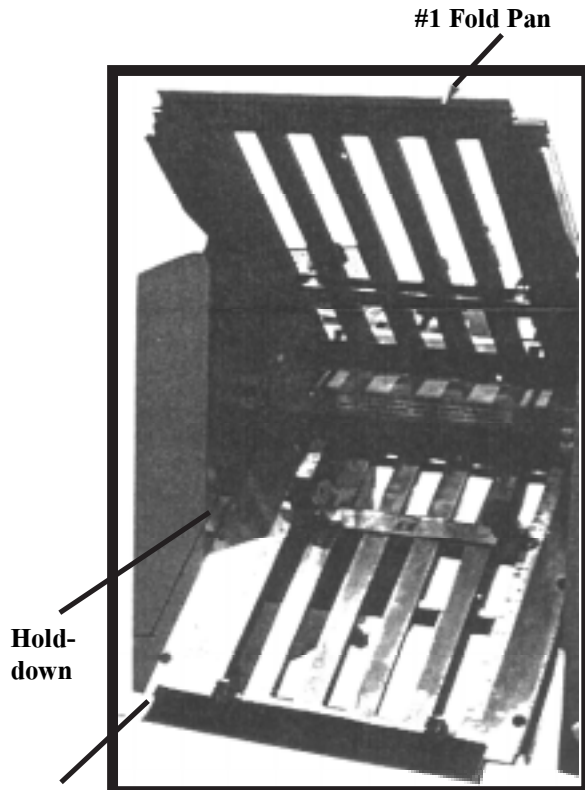

Figure 4.7-1

## 5.0 ELECTRICAL ACCESS

### WARNING

Unplug the AC power cord before attempting any electrical repair.

The motor speed control and counter control are located under the left-hand side cover. The handwheel must be removed for access to these controls.

The cover can be removed by taking out the four screws located on the inside of the frame.

## 6.0 SETUP

### 6.1 Setting The Controls

The operator controls are conveniently located on a control panel on the left-hand side of the 714XLT.

These controls consist of an On/Off power switch, which is an overload reset, a speed control potentiometer, a pump On/Off switch, and a counter with zero reset.

Set these initially at:

- |                  |              |
|------------------|--------------|
| A) Power Switch  | Off position |
| B) Speed Control | "0" position |
| C) Pump Switch   | Off position |
| D) Counter       | "0" position |

### 6.2 Determining Paper Size and Type of Fold

The next step is to determine the paper size and type of fold to be made, following the steps below:

- Measure a sample sheet of the job to be run to determine its size. Retain this information for later use.
- Refer to the printed chart on the stacker tray (See Figure 6.2-1) and locate the type of fold that you want to make. (Example: letter fold)
- Locate on the chart the columns corresponding to the sheet size measured in Step A. (Example: 8 1/2x11)

FOLDING CHART	TYPE OF FOLD	FOLD PAN	8 X 9	8 1/2 X 11	8 1/2 X 14	11 X 17	14 X 20	DEFLECTOR SETTING
BECAUSE THE PAPER SIZE & SQUARENESS VARY, MINOR ADJUSTMENTS OF THE PAPER STOPS MAY BE REQUIRED.  BAUMFOLDER	LETTER FOLD	1ST 2ND	C C	E E	H H	L L	N N	TWO FOLD POSITION
	FAN FOLD	1ST 2ND	M C	R E	U H	X L	Z N	TWO FOLD POSITION
	DOUBLE PARALLEL FOLD	1ST 2ND	G A	K D	P D	T F	V J	TWO FOLD POSITION
	SINGLE FOLD	1ST 2ND	G -	K -	P -	T -	V -	SINGLE FOLD POSITION
	FRENCH FOLD	1ST 2ND	G -	K -	P -	T -	V -	SINGLE FOLD POSITION & ONE SCORING ROLLER
	DOUBLE LETTER FOLD	1ST 2ND	G -	K -	P -	T -	V -	SINGLE FOLD POSITION & TWO SCORING ROLLERS
	ENGINEERING FOLD	1ST 2ND				W O	Y F	TWO FOLD POSITION

Figure 6.2-1

D) Locate the point on the chart where the columns for the type of fold and the sheet size intersect. You will notice that there are either two letters or a dash and a letter. These letters and/or dash tell you where to set the paper stop on the fold plate, and whether or not one of the fold plates will be installed in the deflector position.

Example #1 ; To make a letter fold to an 8 1/2 x11 sheet, set the paper stops for the #1 and #2 fold plates on the letter E. No dash appears, so neither fold plate is installed in the deflector position.

Example #2: To make a single fold to an 8 1/2x11 sheet, install the #2 fold plate in the deflector position. Set the paper stop for the #1 fold plate at the letter K.

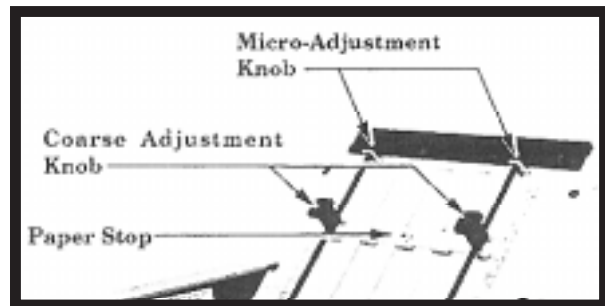

Figure 6.3-1

### 6.3 Paper Stop Adjustment

To move the paper stops to the correct position as determined in step #2, depress the coarse adjustment knobs on the paper stop and slide the paper stop until the indicating edge is aligned with the proper letter on the fold plate. (See Figure 6.3-1)

To obtain an exact setting on the paper stops, turn the micro-adjustment knobs until the indicating edge of the paper stop is perfectly aligned with the line adjacent to the letter on the plate.

### 6.4 Gap Adjustment

With the machine running, insert two sheets of paper between the tab and the sucker wheel. Turn the gap knob counterclockwise until there is a slight drag on the paper. Remove the paper. The correct gap is now set. (See Figure 6.4-1)

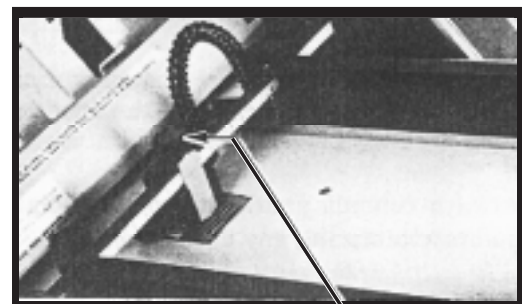

Gap Knob

Figure 6.4-1



## 6.5 Feed Table Adjustment

On the paper feed table there are two guides which keep the stack of paper properly aligned for feeding into the folder. Adjust these guides to correspond with the different widths of paper being fed. (See Figure 6.5-1)

To adjust the paper feed guides, loosen the two side guide locking knobs on each guide. Slide the guides from side to side until the inside edge of each guide is aligned with the number corresponding to the width of the paper being folded.

Example: For an 8 1/2-in wide sheet, move the side guides until the inside edges align with the “8 1/2” on the feed table.

An additional check is to lay a sheet of paper on the feeder, close to but not touching the side guides. Push the sheet down into the nip of the fold rolls. Then align the guide by loosening the adjusting knobs and aligning the guide so that it is parallel to the edge of the paper. When one side is square, the other side can be moved into position.

Tighten the locking knobs to secure the paper guides in position.

When you load the actual job, you may have to move these guides slightly to take care of variations in sheet size. To feed properly, the paper must slide freely between these guides.

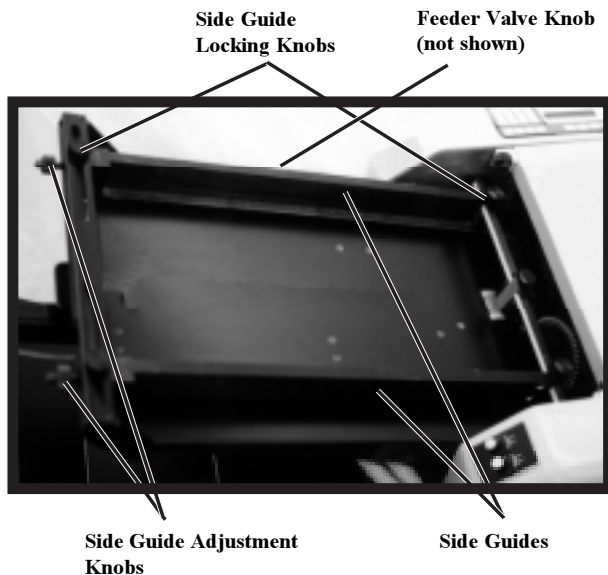

Figure 6.5-1

## 6.6 Air Blow Adjustment

Turn the air blow adjustment on the vacuum/aircontrol panel fully counterclockwise to the + position. Except for when very small sheets are being run, the air blow adjustment is left adjusted for maximum air. (See Figure 6.6-1)

Once the amount of air blow has been selected using the air blow adjustment, the feeder valve knob may be used to direct the air (See Figure 6.5-1).

Turn the knob to the right to obtain more blow on the right side and front of the feed table. Turn the knob to the left to obtain more blow on the left side and lessen the front blow.

Turn the vacuum adjustment clockwise all the way down. This setting is used for most light and medium papers. Heavy paper will require more vacuum.

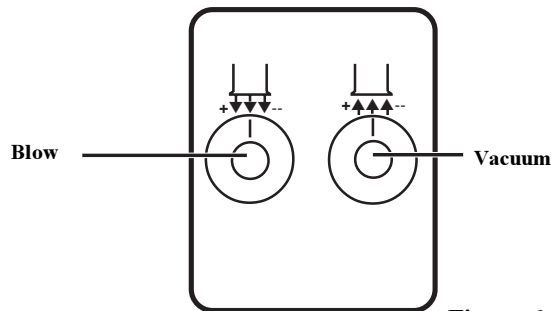

Figure 6.6-1

## 7.0 OPERATION

### 7.1 Loading of Feed Table

Before you can load the paper on the feed table, you must determine which way the paper is to be loaded by running a few sample sheets. (Example: printing face up or face down)

Then you can load a stack of paper no higher than two inches between the paper feed guides. Let the stack slide freely down into position between the side guides.

### 7.2 Starting the Vacuum/Air Feeder

After the vacuum and air adjustments have been made, start the folder, then start the vacuum/pump.

Additional paper can be loaded on top of the stack of paper already in the feeder without stopping the machine.

If the feeder runs out of paper or if you want to stop the machine for any reason, first turn off the vacuum pump, then the folder.

### 7.3 Check Squareness of Fold

Examine the folded sheets on the stacker to make sure that you are getting an even and square fold.

There is a skew adjustment on each plate to adjust for a square fold on paper that is not cut square (See figure 4.7-1).

### 7.4 Use of Handwheel

The handwheel is used to help clear jams and for setup. To use the handwheel, shut off the folder, pull out the handwheel and turn it in either direction.

## 8.0 PERFORATING, SCORING & SLITTING

In addition to folding, your 714XLT Air Feed can perforate, score and slit.

### WARNING

Be careful when handling perforator and slitting blades. They are extremely sharp.

### 8.1 Perforating

The 714XLT can be used to perforate either the folded sheet (to assist in making a right-angle fold) or to perforate sheets delivered flat. BAUMFOLDER supplies one standard 41-tooth perforator blade. Additional perforator blades are available through the BAUMFOLDER Parts Department.

The perforator blade should be mounted loosely to the blade holder with the retainer collar to give better support to the perforator blade. Always be sure that the flat side of the blade is against the blade holder. Loosen the brass-tipped set screws in the perforator collar and blade holder before attempting to place them on the slitter shafts.

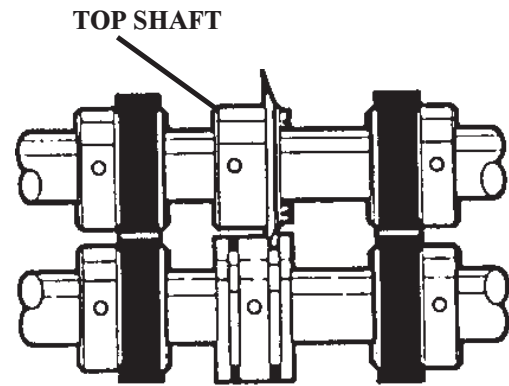

Figure 8.1-1

The perforating blade holder assembly is then slid onto the upper slitter shaft along with the necessary pull-out tire assemblies. Then tighten the screws holding the perforator blade to the blade holder, aligning the blade to the holder. This allows for free horizontal movement on the shaft.

Slide the grooved perforator collar onto the lower slitter shaft along with the other pull-out tire assemblies. The flat side of the perforator blade should just touch the side of the groove in the perforator collar. (See Figure 8.1-1)

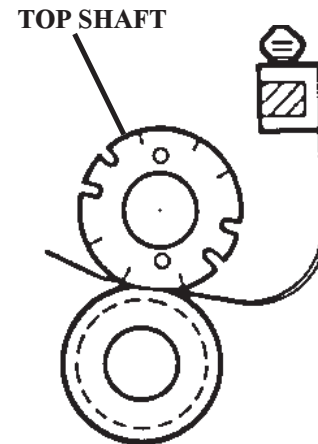

Figure 8.1-2

Slide the perforator collar and blade holder to the desired position on the slitter shaft. Then lock the blade holder and perforator collar into position with the brass-tipped set screw.

The perforator stripper fits onto the slitter shaft bar in between or next to the perforating blade. (See Figure 8.1-2) This strips the paper off for delivery and prevents it from wrapping around the perforator blade.

## 8.2 Scoring

The 714XLT can be used to score a sheet and deliver it flat, or to score a sheet after a fold or folds have been made.

To ensure accuracy in making right-angle folds, always score the sheet where the fold is to be made. This applies in all instances when a perforator cannot be used.

Attach the scoring blade loosely to the blade holder for mounting on the slitter shaft. Scoring blades can be mounted on either the upper or lower slitter shaft. Once on the shaft, tighten the screws, aligning both the blade and the collar. This allows free horizontal movement on the shaft. Scoring blades should be placed so that the fold will be made with rather than against the scoring, or, in a continuing direction to the pressure of the crease that has been applied by the scoring blade.

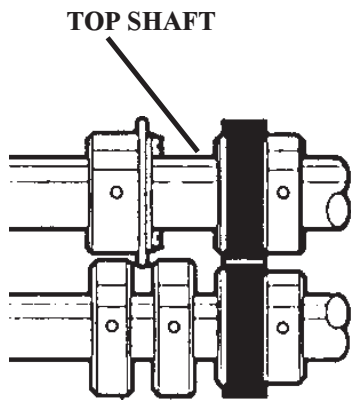

Figure 8.2-1

For a wide, well-rounded score, use the two steel scoring collars. (See Figure 8.2-1) Sharpness and the depth of the score can be controlled by regulating the distance the collars are placed away from the scoring blade.

The scoring collars can also be placed on either side of the rubber scoring collar. The two collars can be compressed against the rubber collar, causing the rubber to bulge up for a deeper score. (See Figure 8.2-2)

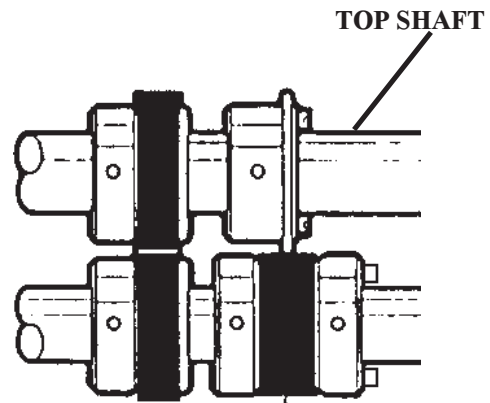

Figure 8.2-2

## 8.3 Slitting

**NOTE:** Slitting accessories are optional on your 714XLT and can be ordered from your BAUMFOLDER Parts Department.

The 714XLT can be used to cut folded or flat sheets apart. The general setup for blades and collars is shown in (Figure 8.3.1). Two or more cuts may be made if duplicate sets of cutters are used.

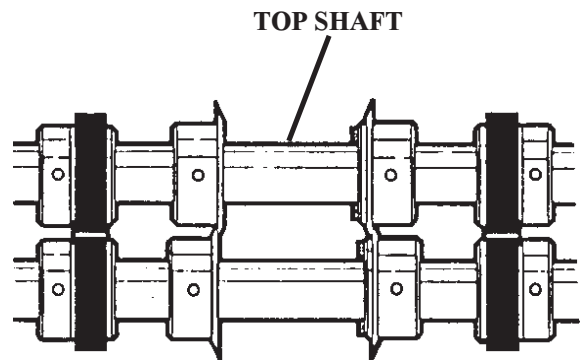

Figure 8.3.-1

Use care in mounting slitter blades to the collars in order to avoid ragged edges during slitting operations. Ragged edges can be caused by two conditions:

- 1) Nicks or burrs on the collars or blades. Remove carefully by filing or using a fine piece of emery cloth.
- 2) Incorrect mounting of blades caused by tightening with the wrong type of screw. Always use flat head screws on the side of the blade and blade holder collar, which are countersunk.

Before tightening the blade to the collar, slide the blade with the collar loosely attached on the end of the shaft. Then tighten securely, thus aligning both the blade and collar, allowing free horizontal movement along the shaft.

Place the blade, mounted on the collar, on the upper shaft in the proper position where the cut is to be made. Then move the blade and collar on the lower shaft so that the two flat edges of the blades are pressed snugly together. Too much space between the blades will produce a ragged cut.

Space the rubber pull-out tires to support the sheet.

## **9.0 MAINTENANCE**

### **9.1 Maintenance and Care of your 714XLT**

The 714XLT Air Feed has been designed to give you years of useful service, provided you maintain it according to these instructions.

### **9.2 Lubrication**

Apply one or two drops of light machine oil at all slitter shaft bearings and the feed table bearings and idler gear once a week. Be sure to keep oil off any surface which may contact the paper.

### **9.3 Cleaning of Fold Rolls**

Periodically wipe off the rubber surface of the fold rolls using an approved solvent such as Surewash or its equivalent. Surewash is available from BAUMFOLDER in 1-quart (P/N 24108-001) and 1-gallon (P/N 24108-002) containers. A complementary bottle of Surewash is included with your machine.

### **9.4 Cleaning Filters**

The filters on the pump should be checked periodically and cleaned as needed. The filters can be reached by unscrewing the filter jars.

### **9.5 Photo Eyes**

Occasionally wipe off the photo eye with a dry cloth.

## **9.6 Cleaning The Fold Stop Guides**

The fold stop guides (See figure 4.7-1) should be cleaned once a week with a dry cloth to keep the plate moving properly.

## **9.7 Replacement Parts**

To order replacement parts for your 714XLT Air Feed, contact BAUMFOLDER Parts Department toll free, **800-543-6107**.

Always be sure to give the model number and serial number of your 714XLT to ensure receiving the proper parts.

**SUREWASH**  
**10.0 MATERIAL SAFETY DATA**  
**SHEET**

**NOTICE:** Surewash is a product of RBP Chemical Corporation, 150 S. 118th St., P.O. Box 14069, Milwaukee, Wisconsin 53214-0069. Tel. 414/258-0911, 800/558-0747.

H M I S R A T I N G

Health: 1  
Flammability: 2  
Reactivity: 0  
Personal Protection: 8

**HAZARDOUS INGREDIENTS**

Name: Medium Aliphatic Solvent Naptha  
(Syn: 140 HF Mineral Spirits)  
CAS#: 64742-88-7  
ACGIH TLV: 100ppm  
OSHA PEL: 500ppm  
%: <95

**PHYSICAL/CHEMICAL CHARACTERISTICS**

Boiling Point: ND  
Solubility in Water: Insoluble  
% Volatiles (by vol.): 95  
Specific Gravity: 0.786  
Appearance and Odor: Clear, light blue liquid with pleasant odor.

**FIRE AND EXPLOSION HAZARD DATA**

Flash Point: 140° F  
Extinguishing Media: CO<sub>2</sub>, Dry chemical, Foam  
Special Fire Fighting Procedures: Wear self-contained breathing apparatus for any fire involving chemicals.  
Unusual Fire and Explosion Hazards: None

**REACTIVITY DATA**

Stability: Stable  
Incompatibility: Strong oxidizers  
Hazardous Decomposition By-products: Carbon dioxide/monoxide  
Hazardous Polymerization: Will not occur  
Conditions to Avoid: Heat, Sparks, and Open Flames

**HEALTH HAZARD DATA**

Routes of Entry: Inhalation, Primary; Skin, Secondary; Ingestion, Unlikely  
Health Hazards Acute and Chronic: Chronic Inhalation of high concentrations may cause respiratory tract

irritation and may affect central nervous system. May cause skin irritation. Chronic over-exposure to many petroleum hydrocarbons may cause liver or kidney injury. May cause eye irritation.

**Emergency & First Aid Prodedures:**

Skin Contact: Wash affected area with soap and water. Remove contaminated clothing.

Eye contact: Flush eyes with water for at least 15 minutes. Consult a physician.

Inhalation: Remove to fresh air. Restore breathing if required. Get medical attention.

Ingestion: DO NOT induce vomiting. Get medical attention.

Carcinogenicity: None of the ingredients in this product are listed by IARC, NTP, or OSHA as carcinogenic.

Signs and Symptoms of Over-exposure: Headache, dizziness, nausea, irritation of the mucous membranes, respiratory tract irritation or mild narcosis at high concentrations.

Medical Conditions Aggravated by Exposure: May aggravate an existing dermatitis.

**PRECAUTIONS FOR USE AND DISPOSAL**

Spills: Small spills can be soaked up with suitable absorbent. For large spills, dike the spill and pump to salvage tank.

Waste Disposal: Incineration or absorbent disposal according to local, state, or federal regulations.

Special Storage/Handling Precautions: None

**CONTROL MEASURES**

Respiratory Protection: Organic vapor respirator for concentrations above the TLV.

Ventilation: Mechanical

Eye Protection: Recommended

Gloves: Recommended, butyl, rubber or neoprene.

Other: Eye bath or safety shower should be located in the work place when working with chemicals.

\*ND = No data found or not determined.

The information contained herein is furnished without warranty of any kind. Users should consider this data a supplement to other information gathered by them and are responsible for completeness of information to assure proper use of these materials and the safety and health of their employees.

To order Surewash call toll free, 800/543-6107  
Part numbers: 24108-001 (quart) & 24108-002 (gallon)