

BAUMFOLDER  
CORPORATION  
Quality Bindery Equipment Since 1917



**714XLT**

**AIR FEED FOLDER**

**COUNTER RETROFIT KIT**

© 2001  
All Rights Reserved

**WARNING**

- Do not operate this machine without all guarding in place.
- Do not make adjustments or perform maintenance on this machine with power on.
- Keep the machine and the work area clean and free of spills to prevent accidents.
- Be sure to replace any safety decals that may have been detached for any reason.

Baumfolder reserves the right to make changes in design or to make additions or improvements in its products without imposing any obligation upon itself to install them on its products previously manufactured. It is recommended that modifications to this equipment not be made without the advice and express written consent of Baumfolder.

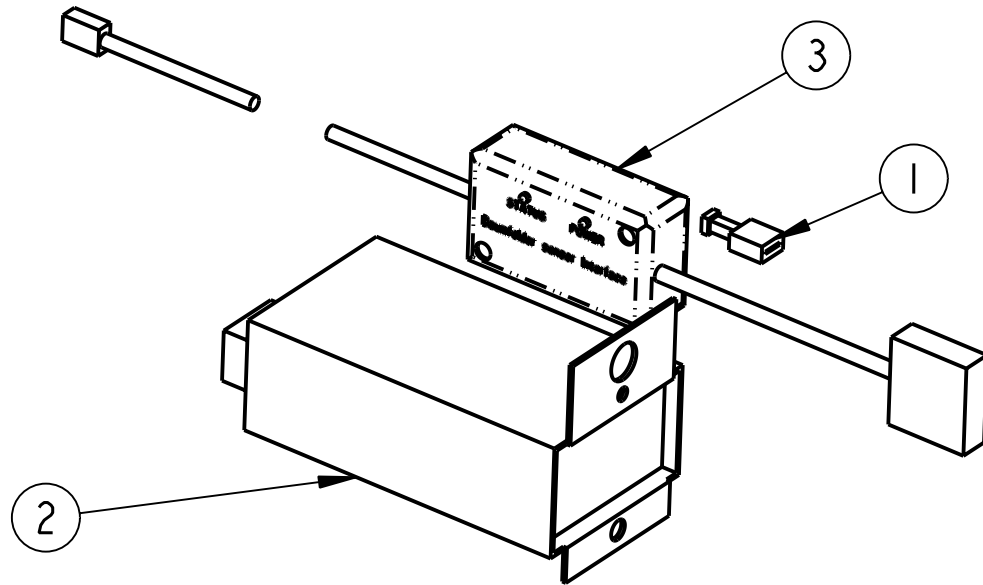

FK2000252			
ITEM #	PART DESCRIPTION	PART #	QTY.
1	TERM-SLIPON, FULLY INS. 22-18AWG	261-362-07-00	1
2	COUNTER HEAD	268-593-01-00	1
3	INTERFACE, 714 SENSOR	FK7000304	1
4	INSTRUCTIONS, COUNTER INSTALLATION	TP10387	1

\*

\* - NOT SHOWN

NOTE:

1. REPLACE THE RING TERMINAL ON THE COUNTER LINE CORD SET WITH THE F.I. SLIPON TERMINAL



DESCRIPTION: KIT, 714 COUNTER

UNIT NAME: 714XLT AIR FEED FOLDER

ASSEMBLY NUMBER:

**FK2000252**

REV:

SHEET 1 OF 1

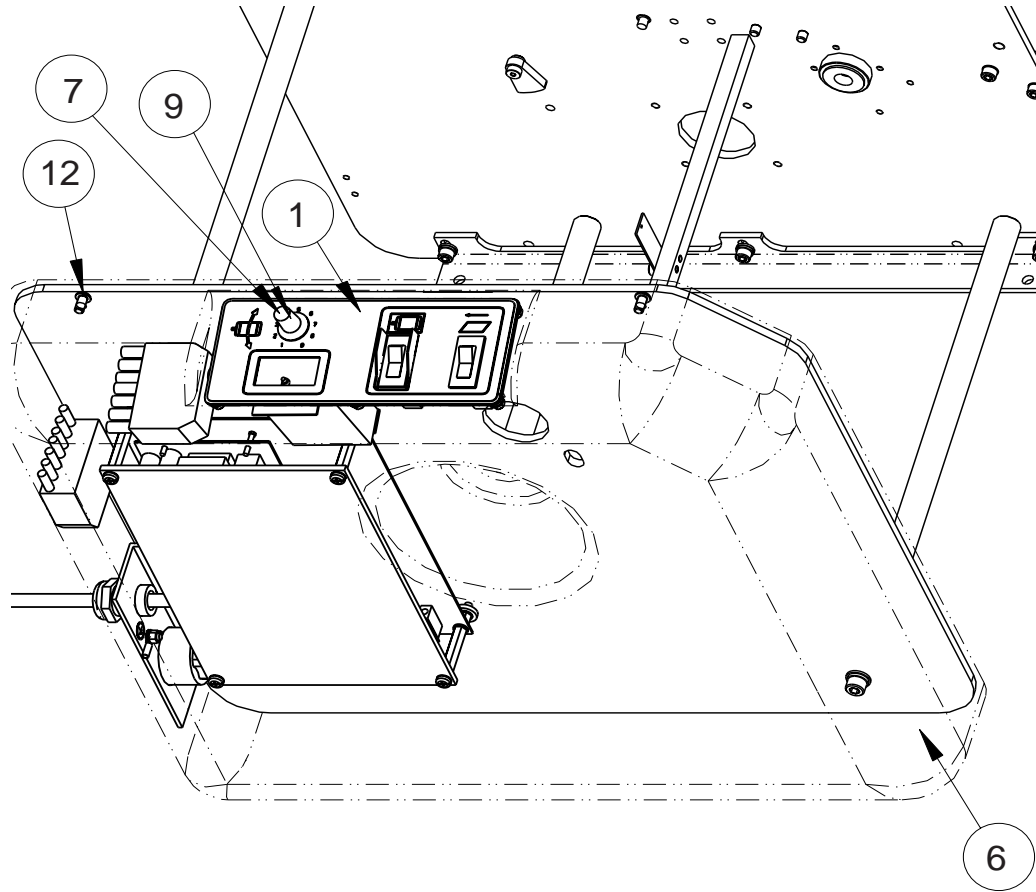

FOR BALLOON IDENTIFICATION REFER TO SECTION 11-68 THRU -72 OF TP10289-1



DESCRIPTION: MAIN ELECTRICAL CONTROL ASSY

ASSEMBLY NUMBER:

**264-892-BG-01**

UNIT NAME: 714XLT AIR FEED FOLDER

REV:

SHEET 1 OF 1

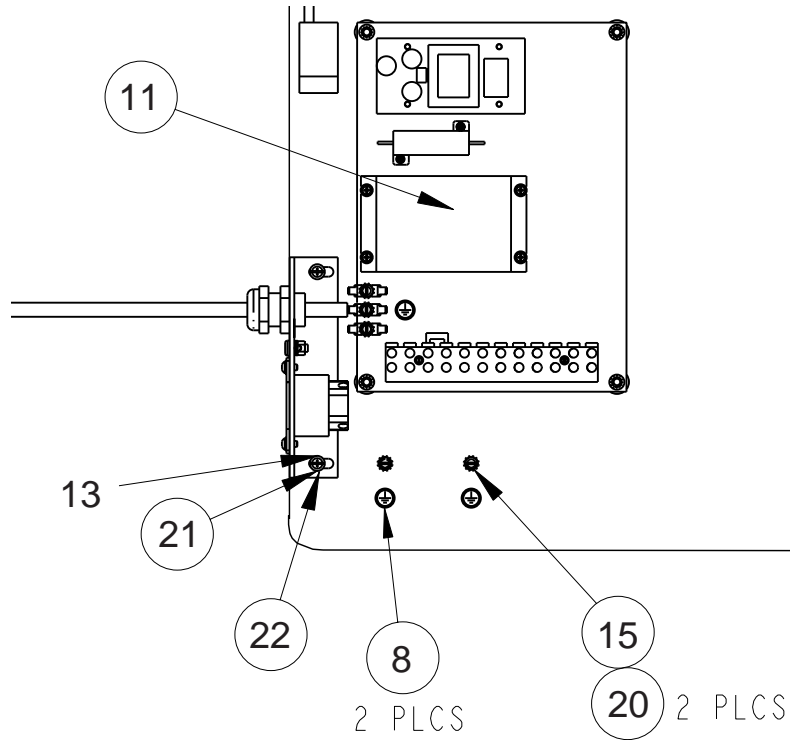

FOR BALLOON IDENTIFICATION REFER TO SECTION 11-68 THRU -72 OF TP10289-1



DESCRIPTION: MAIN ELECTRICAL CONTROL ASSY

UNIT NAME: 714XLT AIR FEED FOLDER

ASSEMBLY NUMBER:

**264-892-BG-01**

REV:

SHEET 1 OF 1

# INSTALLATION INSTRUCTIONS

## REMOVAL OF OLD COUNTER AND RE-ASSEMBLY OF NEW

1. **DISCONNECT POWER FROM MACHINE.** DETACH HANDWHEEL BY REMOVING SCREW AND WASHER FROM MAIN FOLD ROLL SHAFT. REMOVE FOUR (4) BUTTON HEAD SCREWS HOLDING OPERATOR SIDE GUARD TO FOLDER FRAME.
2. TURN SPEED POT KNOB TO “0” AND REMOVE TWO (2) SET SCREWS HOLDING KNOB TO POTENTIOMETER SHAFT. REMOVE NUT AND LOCK WASHER FROM POTENTIOMETER. **NOTE:** THE SHAFT OF POTENTIOMETER IS USED AS A MECHANICAL ATTACHMENT OF THE COUNTER FLANGE TO THE CONTROL PANEL. ALSO REMOVE NUT, FLAT WASHER AND LOCK WASHER WHICH RETAINS THE OPPOSITE COUNTER FLANGE. AT THIS POINT CAREFULLY REMOVE COUNTER FROM CONTROL PANEL SO AS NOT TO DAMAGE RED LENSE THAT IS ADHERED TO CONTROL PANEL.
3. DISCONNECT TWO (2) RED WIRES FROM POWER SUPPLY CIRCUIT BOARD TO “L1” AND “N” ON TB1 OF SUB PANEL BELOW. THERE ARE FOUR (4) PLASTIC STANDOFF’S HOLDING POWER SUPPLY CIRCUIT BOARD TO SUB PANEL. PINCH TOP PORTION OF STANDOFF’S AND REMOVE POWER SUPPLY CIRCUIT BOARD.
4. **DO NOT REMOVE PHOTOEYE SENSOR FORM FOLDER!!!** THE EXISTING SENSOR CABLE WITH CONNECTOR WILL BE USED AND CONNECTED TO NEW BAUMFOLDER SENSOR INTERFACE.
5. INSTALL NEW COUNTER PART NO. **268-593-01-00** INTO FOLDER. **NOTE:** THE NEW COUNTER IS THE SAME CONFIGURATION AS THE OLD. BE CERTAIN NOT TO DAMAGE RED LENSE OF CONTROL PANEL. ATTACH NUT, FLAT WASHER AND LOCK WASHER TO STUD OF CONTROL PANEL TO HOLD BACK FLANGE. RE-INSTALL POTENTIOMETER TO OTHER FLANGE WITH LOCK WASHER AND NUT. TURN SHAFT OF POTENTIOMETER COUNTER CLOCK WISE UNTIL IT STOPS, THIS PUTS POSITION AT “0”. RE-INSTALL KNOB WITH INDICATER AT “0” AND TIGHTEN SET SCREWS.
6. INSTALL NEW BAUMFOLDER SENSOR INTERFACE PART NO. **FK7000304**. PLUG THE SMALL WHITE THREE(3) PIN CONNECTOR INTO BOTTOM OF COUNTER. AT THE OTHER END OF SENSOR INTERFACE YOU WILL FIND A WHITE FOUR (4) PIN CONNECTOR, PLUG THIS INTO THE EXISTING SENSOR CABLE COMING THROUGH FRAME. CONNECT CABLE WITH BLACK THREE (3) PIN CONNECTOR INTO BACK OF COUNTER. CONNECT OPPOSITE END OF THIS CABLE AS FOLLOWS: **CABLE WIRE #1 TO TB1-L1, CABLE WIRE #2 TO TB1-N.** REMOVE RING TERMINAL FROM **GREEN/YELLOW** WIRE AND ATTACH TERMINAL PART NUMBER **261-362-07-00 (SUPPLIED WITH KIT)** TO WIRE, CONNECT THIS WIRE TO ONE OF THE FREE GROUND TERMINAL TABS UP AND SLIGHTLY LEFT OF TB1.
7. WHEN REPLACING OPERATOR SIDE GUARD INTERFERENCE MAY EXIST BETWEEN THE BLACK THREE (3) PIN CONNECTOR OF COUNTER AND HEX STANDOFF SPACER ATTACHING SAFETY COVER TO ELECTRICAL SUB PANEL. IN THIS CASE REMOVE SCREW AND WASHER FROM SAFETY COVER AND DETACH HEX STANDOFF SPACER. RE-INSTALL SCREW AND WASHER REMOVED ABOVE AND FASTEN CORNER OF ELECTRICAL SUB PANEL TO HEX STANDOFF LOCATED BETWEEN SUB PANEL AND OPERATOR SIDE FRAME. **REPLACE GUARD, APPLY POWER AND RESUME FOLDING**

Baumfolder has authorized dealers located throughout the United States.

Call toll free, **1-800/543-6107** for parts or the number of your nearest authorized dealer.

**BAUMFOLDER  
CORPORATION**

*Quality Bindery Equipment Since 1917*

1660 Campbell Road  
Sidney, Ohio 45365-0728  
Phone: 937/492-1281 or 800/543-6107  
Fax: 800/452-0947  
Internet: [www.baumfolder.com](http://www.baumfolder.com)  
E-mail: [baum@bright.net](mailto:baum@bright.net)

