

BAUM Hopper Loader Solutions Comparison Chart

Application	Pocket	HSL-200T	HSL-201T	HSL-210	HSL-310	HSL-400	HSL-450	BHLA-S-A4TS-?	BHLC-P-A4-?
Binder	RG-318	X		X					X
Binder	RG-321		X*						X
Binder	RG-324		X*						X
Stitcher	P-15					X	X		
Stitcher	P-311					X	X		
Stitcher	V-311						X		
Stitcher	V-22						X		
Stitcher	H-311				X				
Stitcher	H-22				X				
Stitcher	Mueller 387						X		
Stitcher	Mueller 416				X				
Stitcher	SP1000							X	
Extension	6 FT BHL							X	X
Extension	10 FT BHL							X	X
Loader application comments:	Works better with 12-page signatures and up Max size 13.25	Max size 14.5	Works better with 2, 4 & 8-page signatures thin forms, gimmick forms, scent strip and unbalanced forms Max size 12	Backpack assembly needed Max size 13.38	Does not like order forms or 8-page signatures Max size 13.38	Pocket modification not required. Will drop sigs into any feedrack & work Max size 12.63	Max size 14	Max size 14	

X* Pocket is able to run larger product than what the hopper loader can feed.

BAUM Hopper Loader Solutions



FOLDERS • CUTTERS • DRILLS • PRESS • FINISHING • GENUINE PARTS
 Internet: <http://www.baumfolder.com> • e-mail: Baumfolder@baumfolder.com



1660 Campbell Road
 Sidney, Ohio 45365
 800/543-6107

BAUM Hopper Loader & Extension Solutions

BAUM has an extensive selection of hopper loaders adaptable to many different manufacturers' saddle stitching, perfect binding, co-mailing equipment and other applications. BAUM hopper loaders provide positive control over printed products, especially compared to hand feeding and other outmoded methods, by reducing labor costs as much as 50% or more.

Optimum pile height and excellent jog quality are provided so that feeding proceeds uninterrupted. The superior signature handling provides greater benefits of throughput, enhancing productivity and reducing waste. Additional savings are achieved due to less labor required down-line due to consistent feeding.

BAUM has multiple solutions to adapt to both vertical and horizontal pocket designs, and various manufacturers' controls systems. The complete line also includes extensions to the BAUM line and to select other existing hopper loaders to further increase productivity.

The BAUM line offers several variations and equipment configurations that will adapt to most manufacturers' binding, co-mailing and processing equipment.

Our in-house design team combined with our world-class manufacturing facility can provide key solutions for:

- Thick Shingle Feeding
- Thin Shingle Feeding
- Bulk Product Feeding
- Add-on Extensions for more productivity



FOLDERS • CUTTERS • DRILLS • PRESS • FINISHING • GENUINE PARTS
Internet: <http://www.baumfolder.com> • e-mail: Baumfolder@baumfolder.com

1660 Campbell Road, Sidney, Ohio 45365 800/543-6107

Horizontal RG Gatherer Loaders

HSL-200T

Thick-Shingled, Spine Leading with Telescoping Delivery.

HSL-201T

Thick-Shingled, Spine Leading with Telescoping Delivery, wider product with RG324.

HSL-210

Thin-Shingled, Spine Leading. Includes Accelerator. (Similar to HSL-310)

BHLC-P-A4

Thick-Shingled, Spine Leading with Telescoping Delivery, hand feeding.

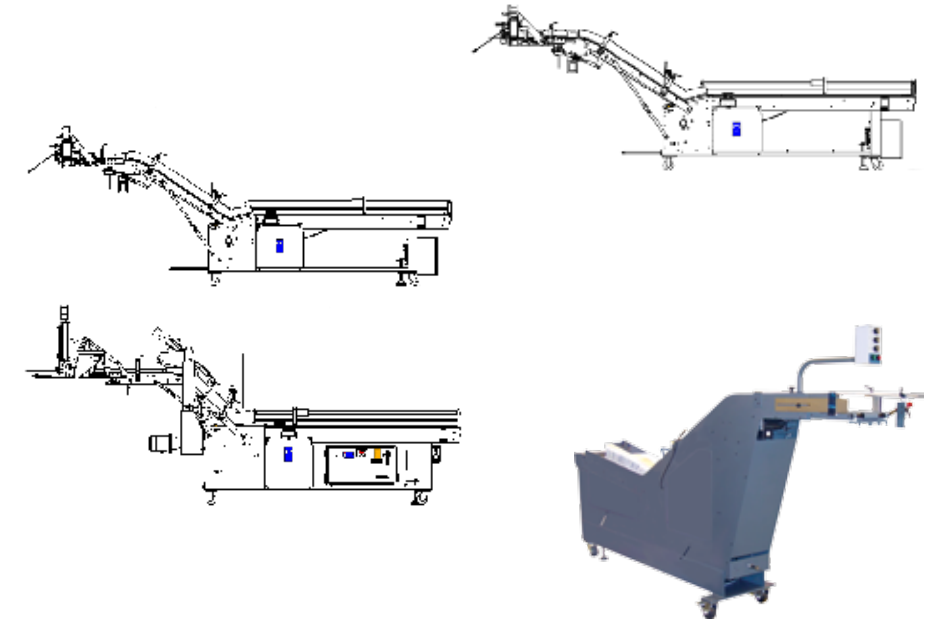

Horizontal Stitcher Pocket Loaders

HSL-310

Thin-Shingled, Spine Trailing. Includes Accelerator. Steeper incline with top belt.

BHLA-S-A4TS

Thin-Shingled, Spine Trailing. Includes Accelerator, hand feeding.

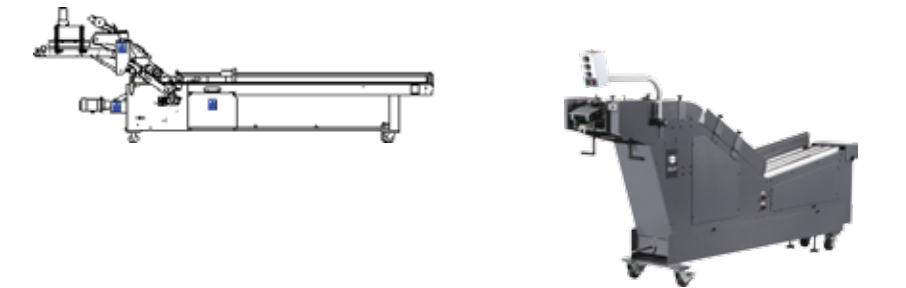

Vertical Stitcher Pocket Loaders

HSL-400

Thick-Shingled, Spine Trailing.

HSL-450

Thin-Shingled, Spine Leading. Flips over stream and delivers from above feed rack.

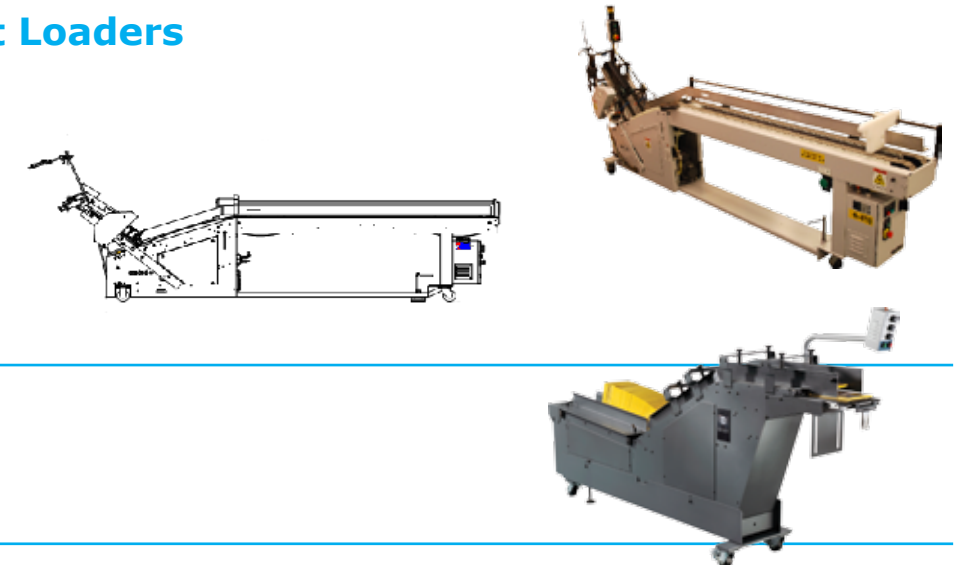

Co-Mailer

BHLB-M-A-4TS-V

Bulk product feeding.

Extensions

BHLA-EXT-6

Six-foot long for log loading.

BHLA-EXT-10

Ten-foot long for log loading.

